

Z50/...

Angießbuchsen-Rohling
Sprue bushing, blank
Buse d'injection

Mat.: 1.2826 / 740 N/mm²

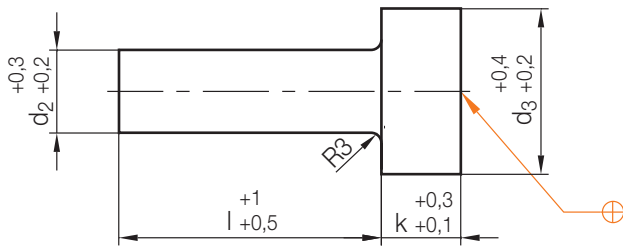

| d ₃ | k | d ₂ | l | Nr./No. |
|----------------|----|----------------|----|-----------|
| 38 | 18 | 18 | 36 | Z50/18x36 |
| | | | 56 | 56 |
| | | | 76 | 76 |

| d ₃ | k | d ₂ | l | Nr./No. |
|----------------|----|----------------|-----|------------|
| 48 | 23 | 24 | 56 | Z50/24x 56 |
| | | | 76 | 76 |
| | | | 96 | 96 |
| | | | 136 | 136 |

Z51/...

Angießbuchse, ohne Kalottenradius
Sprue bushing, without calotte radius
Buse d'injection, sans rayon de calotte

Mat.: 1.2826 / 55 ± 2 HRC
DIN ISO 10072 (DIN 16752)

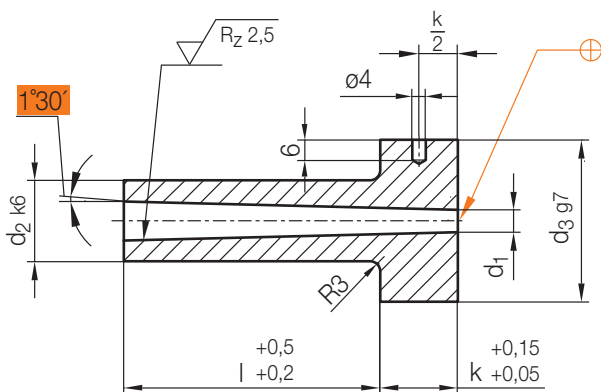

| d ₃ | k | d ₂ | l | d ₁ | Nr./No. | | |
|----------------|----|----------------|----|----------------|---------------|--------|--------|
| 38 | 18 | 18 | 27 | 3,5 | Z51/18x27/3,5 | | |
| | | | | | 36 | 36/3,5 | |
| | | | | | 46 | 46/3,5 | |
| | | | | | 56 | 56/3,5 | |
| | | | 27 | 4,5 | 18 | 76 | 76/3,5 |
| | | | | | | 96 | 96/3,5 |
| | | | | | | 36 | 27/4,5 |
| | | | | | | 46 | 36/4,5 |

| d ₃ | k | d ₂ | l | d ₁ | Nr./No. | |
|----------------|----|----------------|----|----------------|---------------|--------|
| 38 | 18 | 18 | 56 | 4,5 | Z51/18x56/4,5 | |
| | | | | | 76 | 76/4,5 |
| | | | | | 96 | 96/4,5 |
| | | | | | 76 | 76/4,5 |
| 48 | 23 | 24 | 46 | 6,5 | Z51/24x46/4,5 | |
| | | | | | 56 | 56/4,5 |
| | | | | | 76 | 76/4,5 |
| | | | | | 76 | 76/6,5 |

Z51/...

Angießbuchse, Kalottenradius metrisch
 Sprue bushing, calotte radius metric
 Buse d'injection, rayon de calotte metrique

Mat.: 1.2826/55 ± 2 HRC
 DIN ISO 10072 (DIN 16752)

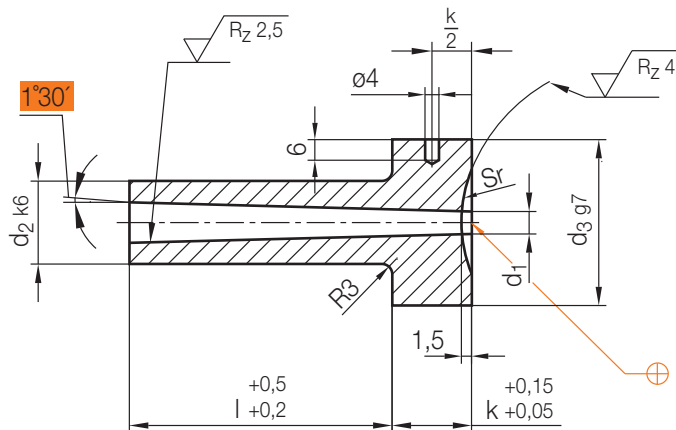

5

| d ₃ | k | d ₂ | l | d ₁ | Sr | Nr./No. | Sr | Nr./No. | | | |
|----------------|-----|--------------------|----|----------------|------------------|--------------------|----|--------------------|------------------|-----|--------------------|
| 38 | 18 | 18 | 27 | 3,5 | 15,5 | Z51/18x27/3,5/15,5 | 40 | Z51/18x27/3,5/40 | | | |
| | | | 36 | | | 36 | | | | | |
| | | | 46 | | | 46 | | | | | |
| | | | 56 | | | 56 | | | | | |
| | | | 76 | | | 76 | | | | | |
| | | | 96 | | | 96 | | | | | |
| | | | 27 | | | 4,5 | | Z51/18x27/4,5/15,5 | Z51/18x27/4,5/40 | | |
| | | | 36 | 36 | | | | | | | |
| | | | 46 | 46 | | | | | | | |
| | | | 56 | 56 | | | | | | | |
| | | | 76 | 76 | | | | | | | |
| | | | 96 | 96 | | | | | | | |
| | | | 48 | 23 | | | | 24 | 46 | 4,5 | Z51/24x46/4,5/15,5 |
| | | | | | | 56 | | | 56 | | |
| 76 | 76 | | | | | | | | | | |
| 56 | 6,5 | Z51/24x56/6,5/15,5 | | | Z51/24x56/6,5/40 | | | | | | |
| 76 | | 76 | | | | | | | | | |
| 56 | | 56 | | | | | | | | | |
| 76 | | 76 | | | | | | | | | |

Z51/...

Angießbuchse, Kalottenradius Inch
 Sprue bushing, calotte radius Inch
 Buse d'injection, rayon de calotte Inch

Mat.: 1.2826/55 ± 2 HRC
 DIN ISO 10072 (DIN 16752)

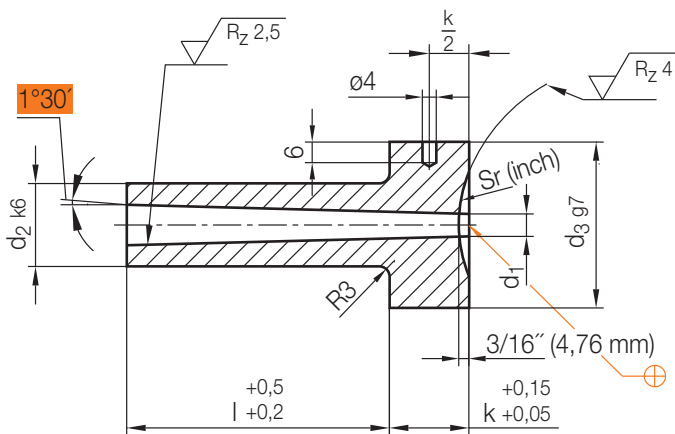

| d ₃ | k | d ₂ | l | d ₁ | Sr | Nr./No. | Sr | Nr./No. |
|----------------|-----|----------------|-----|----------------|-----|--------------------|-----|--------------------|
| 38 | 18 | 18 | 27 | 3,5 | 1/2 | Z51/18x27/3,5/ 1/2 | 3/4 | Z51/18x27/3,5/ 3/4 |
| | | | | 4,5 | | 4,5 | | |
| | | | 36 | 3,5 | | 36/3,5 | | 36/3,5 |
| | | | | 4,5 | | 4,5 | | |
| | | | 46 | 3,5 | | 46/3,5 | | 46/3,5 |
| | | | | 4,5 | | 4,5 | | |
| | | | 56 | 3,5 | | 56/3,5 | | 56/3,5 |
| | | | | 4,5 | | 4,5 | | |
| | | | 66 | 4,5 | | 66/4,5 | | 66/4,5 |
| | | | 76 | 4,5 | | 76/4,5 | | 76/4,5 |
| 48 | 23 | 24 | 46 | 4,5 | 1/2 | Z51/24x46/4,5/ 1/2 | 3/4 | Z51/24x46/4,5/ 3/4 |
| | | | | 56 | | 56/4,5 | | 56/4,5 |
| | | | 6,5 | 6,5 | | 6,5 | | |
| | | | 66 | 4,5 | | 66/4,5 | | 66/4,5 |
| | | | | 6,5 | | 6,5 | | |
| | | | 76 | 4,5 | | 76/4,5 | | 76/4,5 |
| 6,5 | 6,5 | 6,5 | | | | | | |

Z510/...

Angießbuchsen-Rohling
Sprue bushing, blank
Buse d'injection

Mat.: 1.2826/55 HRC
gehärtet/hardened/trempe

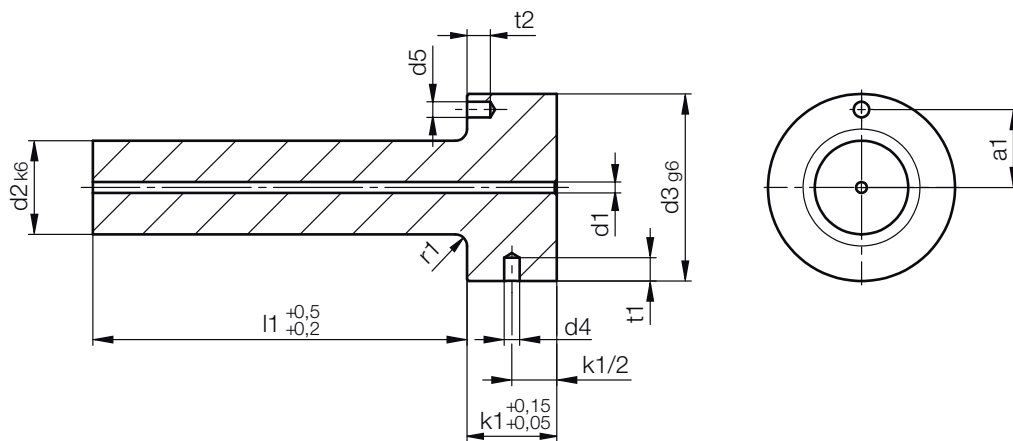
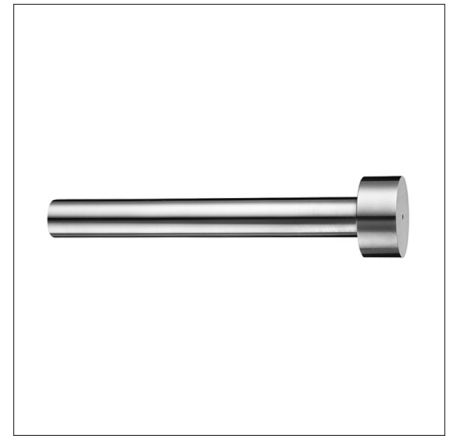

| r1 | k1 | t2 | t1 | a1 | d5 | d4 | d3 | d2 | l1 | d1 | Nr./No. | | |
|----|----|----|-----|-----|----|----|-----|-----------------|----|-----|-----------------|----|----|
| 3 | 13 | 6 | 6 | 11 | 4 | 4 | 28 | 12 | 46 | 1,4 | Z510/12x 46x1,4 | | |
| | | | | 15 | | | | | 38 | | 18 | 96 | 96 |
| | | | | 20 | | | | | | | | 48 | 24 |
| | 18 | | 146 | 146 | | | | | | | | | |
| | | | 176 | 176 | | | | | | | | | |
| | | | 23 | 96 | | | 156 | Z510/24x 96x2,8 | | | | | |
| | | | | | | | | 156 | | 156 | | | |
| | | | | | | | | 196 | | 196 | | | |

Z511/...

Angießbuchse, ohne Kalottenradius
 Sprue bushing, without calotte radius
 Buse d'injection, sans rayon de calotte

Mat.: 1.2826/55 ± 2 HRC
 DIN ISO 10072 (DIN 16752)

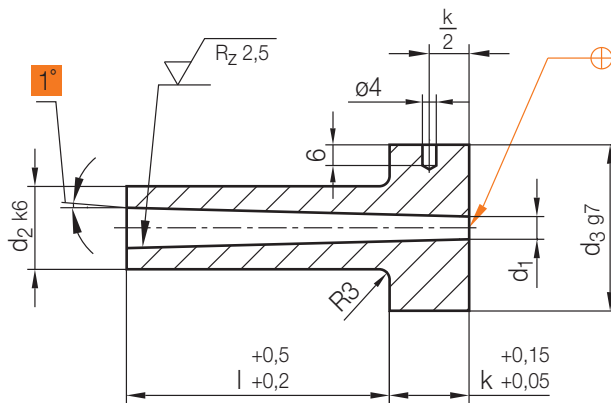

5

| d ₃ | k | d ₂ | l | d ₁ | Nr./No. |
|----------------|-----|----------------|----|----------------|----------------|
| 28 | 13 | 12 | 22 | 2,5 | Z511/12x22/2,5 |
| | | | 27 | | 27 |
| | | | 36 | | 36 |
| | | | 46 | | 46 |
| | | | 22 | | 3,5 |
| | | 27 | 27 | | |
| | | 36 | 36 | | |
| | | 46 | 46 | | |
| | | 56 | 56 | | |
| | | 38 | 18 | 18 | 27 |
| 36 | 36 | | | | |
| 46 | 46 | | | | |
| 56 | 56 | | | | |
| 66 | 66 | | | | |
| 76 | 76 | | | | |
| 86 | 86 | | | | |
| 96 | 96 | | | | |
| 116 | 116 | | | | |
| | | | | | |

| d ₃ | k | d ₂ | l | d ₁ | Nr./No. |
|----------------|----|----------------|-----|----------------|---------------|
| 38 | 18 | 18 | 56 | 3 | Z511/18x 56/3 |
| | | | 66 | | 66 |
| | | | 76 | | 76 |
| | | | 86 | | 86 |
| | | | 96 | | 96 |
| | | | 116 | 116 | |
| | | | | 4 | Z511/18x 27/4 |
| | | | 27 | | 36 |
| | | | 36 | | 46 |
| | | | 46 | | 56 |
| 56 | 66 | | | | |
| | | | | | |

Z511/...

Angießbuchse, Kalottenradius metrisch
 Sprue bushing, calotte radius metric
 Buse d'injection, rayon de calotte metrique

Mat.: 1.2826/55 ± 2 HRC
 DIN ISO 10072 (DIN 16752)

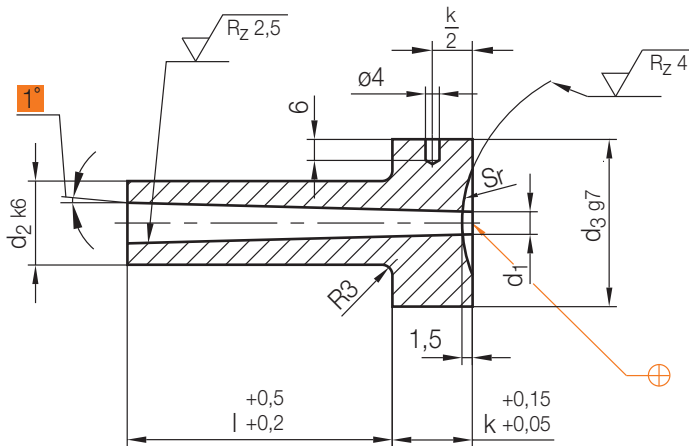

| d ₃ | k | d ₂ | l | d ₁ | Sr | Nr./No. | Sr | Nr./No. | |
|----------------|-----|----------------|----|---------------------|------|----------------------|---------------------|----------------------|--------------------|
| 28 | 13 | 12 | 22 | 2,5 | 15,5 | Z511/12x 22/2,5/15,5 | 40 | Z511/12x 22/2,5/40 | |
| | | | 27 | | | 27 | | | |
| | | | 36 | | | 36 | | | |
| | | | 46 | | | 46 | | | |
| | | | 22 | | | 3,5 | | Z511/12x 22/3,5/15,5 | Z511/12x 22/3,5/40 |
| | | | 27 | | | | | 27 | |
| | 36 | 36 | | | | | | | |
| | 46 | 46 | | | | | | | |
| | 56 | 56 | | | | | | | |
| | 38 | 18 | 18 | 27 | 3 | | Z511/18x 27/3 /15,5 | Z511/18x 27/3 /40 | |
| | 36 | | | 36 | | | | | |
| | 46 | | | 46 | | | | | |
| 56 | 56 | | | | | | | | |
| 66 | 66 | | | | | | | | |
| 76 | 76 | | | | | | | | |
| 86 | 86 | | | | | | | | |
| 96 | 96 | | | | | | | | |
| 116 | 116 | | | | | | | | |
| 27 | 4 | | | Z511/18x 27/4 /15,5 | | Z511/18x 27/4 /40 | | | |
| 36 | | | | 36 | | | | | |
| 46 | | | | 46 | | | | | |
| 56 | | | | 56 | | | | | |
| 66 | | | | 66 | | | | | |
| 76 | | | | 76 | | | | | |
| 86 | | | | 86 | | | | | |
| 96 | | | | 96 | | | | | |
| 116 | | | | 116 | | | | | |

Z511/...

Angießbuchse, Kalottenradius Inch
 Sprue bushing, calotte radius Inch
 Buse d'injection, rayon de calotte Inch

Mat.: 1.2826/55 ± 2 HRC
 DIN ISO 10072 (DIN 16752)

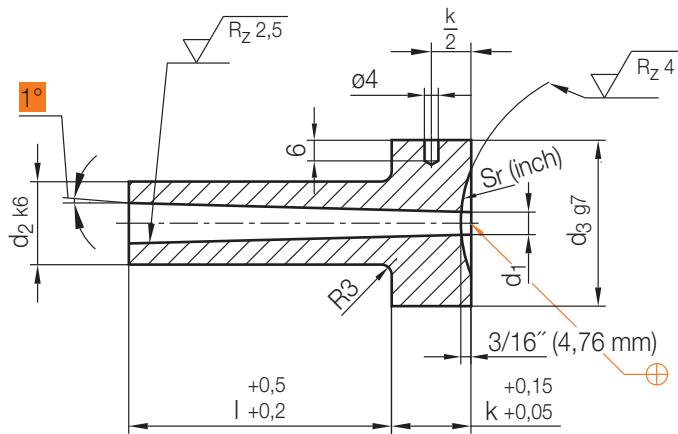

5

| d ₃ | k | d ₂ | l | d ₁ | Sr | Nr./No. | Sr | Nr./No. |
|----------------|----|----------------|-----|----------------|-------|--------------------|-----|--------------------|
| 38 | 18 | 18 | 27 | 3 | 1/2 | Z511/18x 27/3/ 1/2 | 3/4 | Z511/18x 27/3/ 3/4 |
| | | | | 4 | | 4 | | 4 |
| | | | 36 | 3 | 36/3 | 36/3 | | |
| | | | | 4 | 4 | 4 | | |
| | | | 46 | 3 | 46/3 | 46/3 | | |
| | | | | 4 | 4 | 4 | | |
| | | | 56 | 3 | 56/3 | 56/3 | | |
| | | | | 4 | 4 | 4 | | |
| | | | 66 | 3 | 66/3 | 66/3 | | |
| | | | | 4 | 4 | 4 | | |
| | | | 76 | 3 | 76/3 | 76/3 | | |
| | | | | 4 | 4 | 4 | | |
| | | | 86 | 3 | 86/3 | 86/3 | | |
| | | | | 4 | 4 | 4 | | |
| | | | 96 | 3 | 96/3 | 96/3 | | |
| | | | | 4 | 4 | 4 | | |
| | | | 116 | 3 | 116/3 | 116/3 | | |
| | | | | 4 | 4 | 4 | | |

Z512/...

Angießbuchse
Sprue bushing
Buse d'injection

Mat.: 1.2826/55 ± 2 HRC
DIN ISO 10072 (DIN 16752)

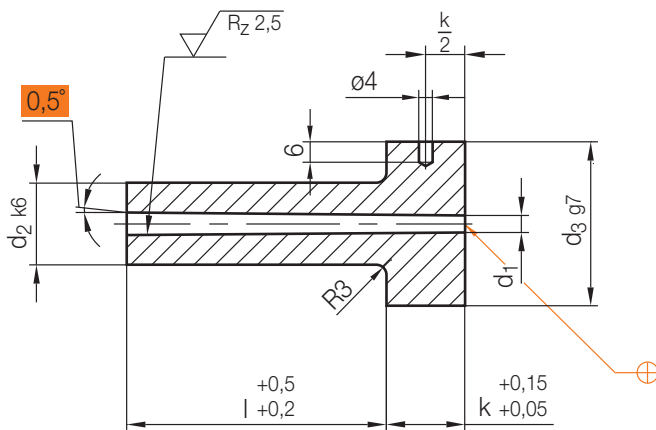

| d ₃ | k | d ₂ | l | d ₁ | Nr./No. |
|----------------|----|----------------|----|----------------|----------------|
| 28 | 13 | 12 | 27 | 2,5 | Z512/12x27/2,5 |
| | | | 36 | | 36 |
| | | | 46 | | 46 |
| | | | 56 | | 56 |
| | | | 36 | | 3,5 |
| | | 46 | 46 | | |
| | | 56 | 56 | | |
| | | 66 | 66 | | |
| | | 76 | 76 | | |
| | | | | | |
| | | | | | |
| | | | | | |
| | | | | | |
| | | | | | |

| d ₃ | k | d ₂ | l | d ₁ | Nr./No. | |
|----------------|----|----------------|-----|----------------|---------------|---------------|
| 38 | 18 | 18 | 46 | 3 | Z512/18x 46/3 | |
| | | | 56 | | 56 | |
| | | | 66 | | 66 | |
| | | | 76 | | 76 | |
| | | | 86 | | 86 | |
| | | | 96 | | 96 | |
| | | | 56 | | 4 | Z512/18x 56/4 |
| | | 66 | 66 | | | |
| | | 76 | 76 | | | |
| | | 86 | 86 | | | |
| | | 96 | 96 | | | |
| | | 116 | 116 | | | |
| | | | | | | |
| | | | | | | |
| | | | | | | |
| | | | | | | |
| | | | | | | |

Z512/...

Angießbuchse
Sprue bushing
Buse d'injection

Mat.: 1.2826/55 ± 2 HRC
DIN ISO 10072 (DIN 16752)

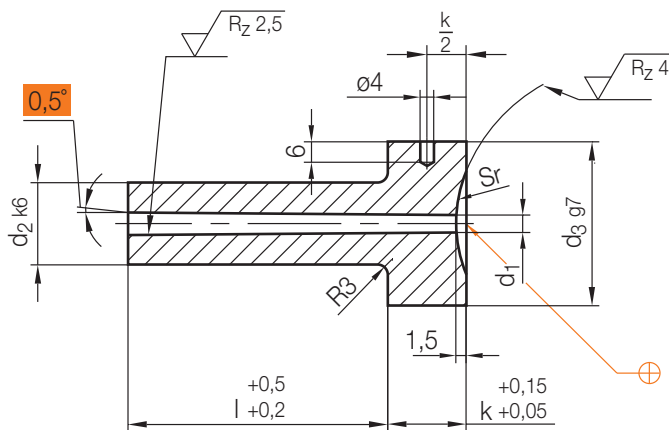

5

| d ₃ | k | d ₂ | l | d ₁ | Sr | Nr./No. | | | | |
|----------------|----|----------------|----|----------------|---------------------|---------------------|-------------------|--|----|----|
| 28 | 13 | 12 | 27 | 2,5 | 15,5 | Z512/12x27/2,5/15,5 | | | | |
| | | | | | | 36 | | | | |
| | | | | | | 46 | | | | |
| | | | | | | 56 | | | | |
| | | | 36 | 3,5 | Z512/12x36/3,5/15,5 | | | | 36 | |
| | | | | | 46 | | | | | |
| | | | | | 56 | | | | | |
| | | | | | 66 | | | | | |
| | | | | | 76 | | | | | |
| | | | | | 76 | | | | | |
| | | 27 | 13 | 12 | 2,5 | 40 | Z512/12x27/2,5/40 | | | |
| | | | | | | | 36 | | | |
| | | | | | | | 46 | | | |
| | | | | | | | 56 | | | |
| | | | | 36 | 3,5 | Z512/12x36/3,5/40 | | | | 36 |
| | | | | | | 46 | | | | |
| | | | | | | 56 | | | | |
| | | | | | | 66 | | | | |
| | | | | | | 76 | | | | |
| | | | | | | 76 | | | | |

| d ₃ | k | d ₂ | l | d ₁ | Sr | Nr./No. | | | | |
|----------------|----|----------------|----|----------------|----------------------|--------------------|----|--------------------|----|----|
| 38 | 18 | 18 | 46 | 3 | 15,5 | Z512/18x 46/3/15,5 | | | | |
| | | | | | | 56 | | | | |
| | | | | | | 66 | | | | |
| | | | | | | 76 | | | | |
| | | | 36 | 3,5 | Z512/18x 36/3,5/15,5 | | | | 36 | |
| | | | | | 46 | | | | | |
| | | | | | 56 | | | | | |
| | | | | | 66 | | | | | |
| | | | | | 76 | | | | | |
| | | | | | 76 | | | | | |
| | | | 27 | 18 | 12 | 2,5 | 40 | Z512/18x 27/2,5/40 | | |
| | | | | | | | | 36 | | |
| | | 46 | | | | | | | | |
| | | 56 | | | | | | | | |
| | | 36 | | | 3,5 | Z512/18x 36/3,5/40 | | | | 36 |
| | | | | | | 46 | | | | |
| | | | | | | 56 | | | | |
| | | | | | | 66 | | | | |
| | | | | | | 76 | | | | |
| | | | | | | 76 | | | | |