

# Z 159/...

Auswerferkupplung, pneumatisch  
 Ejector coupling device, pneumatic  
 Coupleur pneumatique

≈ EUROMAP 11 Part 5

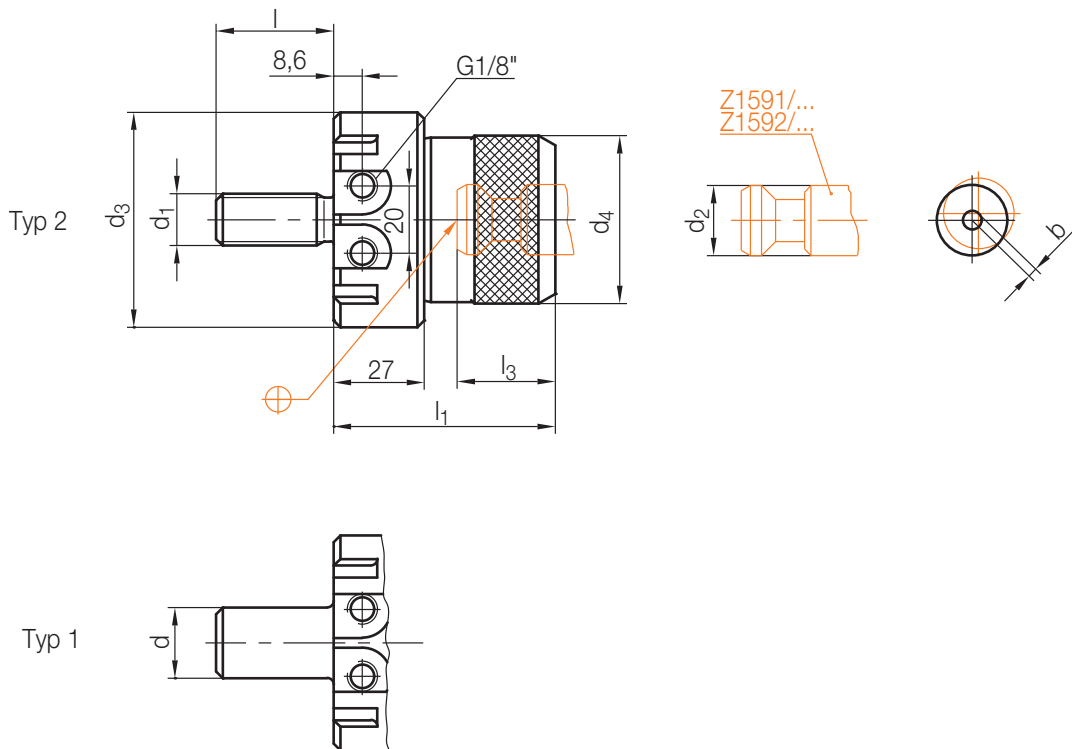

4

Typ	b	d <sub>4</sub>	d <sub>3</sub>	l <sub>3</sub>	l <sub>1</sub>	l	d	d <sub>2</sub>	d <sub>1</sub>	Nr./No.
1	0,7	50	64	20	65	28	20,5	<b>18</b>	—	Z 159/18
<b>M16</b>									18/M16	
1	1,0	60	78	23	70	36	24,5	<b>24</b>	—	24
2									<b>M20</b>	24/M20
1	1,2	70	92	26	75	45	30,5	<b>30</b>	—	30
2									<b>M24</b>	30/M24

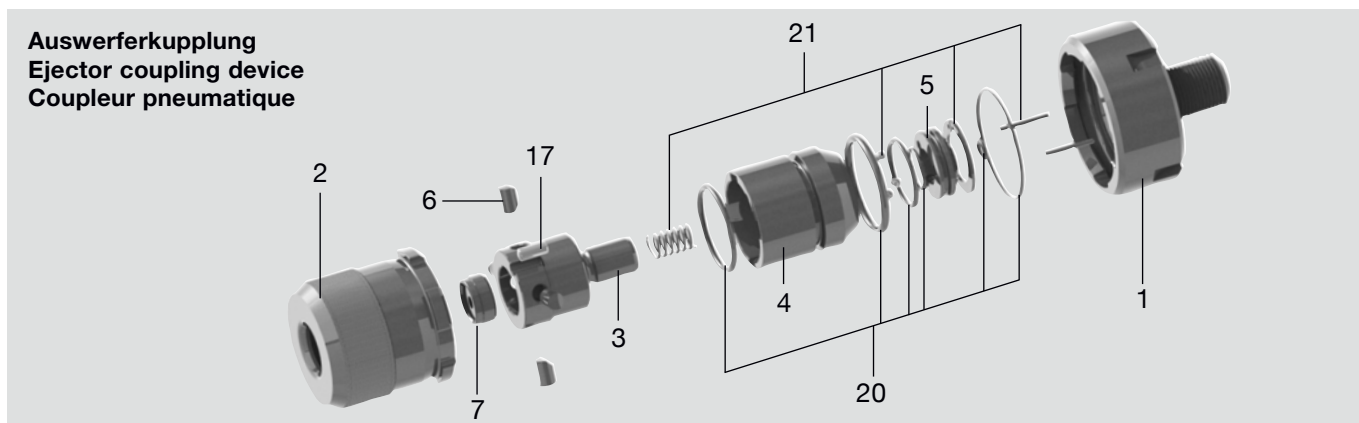

Pos.	Benennung	Designation	Désignation	Stück Quantity Pièce
1	Flansch	Flange	Bride	1
2	Gehäuse	Housing	Boîtier	1
3	Aufnahme	Retainer	Retenue de coulisseau	1
4	Kolben	Piston	Piston de sécurité	1
5	Sicherungskolben	Safety piston	Segment	1
6	Segment	Segment	Segment	4
7	Stützring	Support ring	Bague entretoise	1
17	Zylinderstift	Dowel pin	Goupille cylindrique	1
20	Dichtungssatz	Seal assembly	Pochette de joint	1
21	Montagesatzsatz	Assembly-kit	Kit de montage	1

= Verpackungseinheit / packing unit / unité d'emballage

Nr./No.	1 Z 159/...	2 Z 159/...	3 Z 159/...	4 Z 159/...	5 Z 159/...
Z 159/ 18	18-01/E	18/M16-02/E	18/M16-03/E	18/M16-04/E	18/M16-05/E
18/M16	18/M16-01/E				
Z 159/ 24	24-01/E	24/M20-02/E	24/M20-03/E	24/M20-04/E	24/M20-05/E
24/M20	24/M20-01/E				
Z 159/ 30	30-01/E	30/M24-02/E	30/M24-03/E	30/M24-04/E	30/M24-05/E
30/M24	30/M24-01/E				

Nr./No.	6 Z 159/...	7 Z 159/...	17 Z 25/...	20 Z 159/...	21 Z 159/...
Z 159/ 18	18/M16-06/E	18/M16-07/E	5 x 12	18/M16-20/E	18/M16-21/E
18/M16					
Z 159/ 24	24/M20-06/E	24/M20-07/E	5 x 14	24/M20-20/E	24/M20-21/E
24/M20					
Z 159/ 30	30/M24-06/E	30/M24-07/E	5 x 16	30/M24-20/E	30/M24-21/E
30/M24					

## Z 1591/...

Kupplungszapfen  
Coupling spigot  
Tige d'éjection

Mat.: 1.2764/58 - 3 HRC

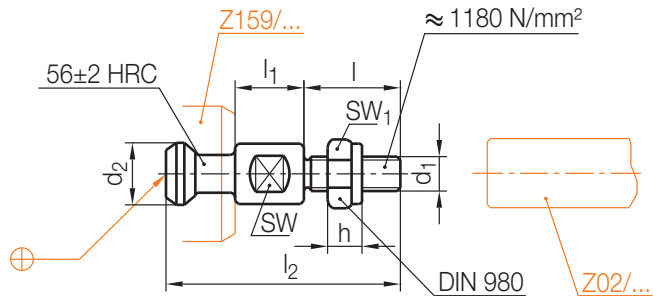
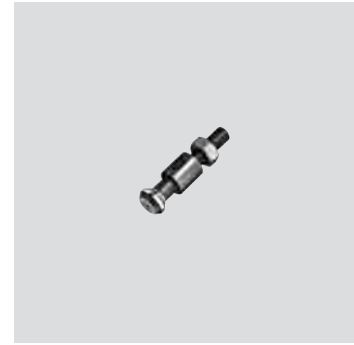

Z28/...	SW	SW <sub>1</sub>	h	l <sub>2</sub>	l	d <sub>1</sub>	d <sub>2</sub>	l <sub>1</sub>	Nr./No.
Z28/10	14	17	7,6	68	28	M10	<b>18</b>	<b>20</b>	Z 1591/18x20
12	19	19	9,6	83	35	M12	<b>24</b>	<b>25</b>	24x25
16	24	24	12,3	101	43	M16	<b>30</b>	<b>32</b>	30x32

## Z 1592/...

Ausstoß-/Kupplungsbolzen  
Ejector/coupling rod  
Ejecteur-coupleur

Mat.: 1.2764/58 - 3 HRC

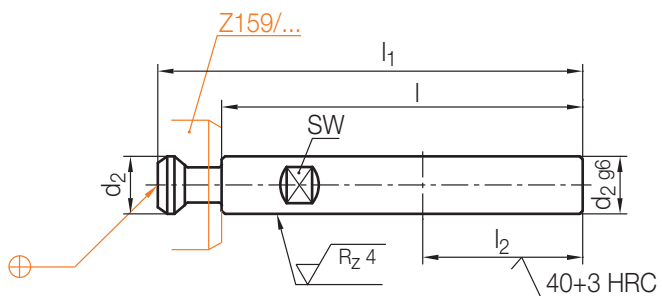

SW	l <sub>2</sub>	l <sub>1</sub>	d <sub>2</sub>	l	Nr./No.
14	50	220	<b>18</b>	<b>200</b>	Z 1592/18x200
19	60	273	<b>24</b>	<b>250</b>	24x250
24	70	306	<b>30</b>	<b>280</b>	30x280