

Firma/Company/Société: _____

Zuständig/Contact/Responsable: _____

Tel.: _____ Fax.: _____ Datum/Date: _____

Bestellung/Order/Commande Nr./No.: _____ Anfrage/Quotation/Demande

Z 466 / ... / S

Flachauswerfer
Flat ejector pin
Ejecteur lame

Mat.: WS* (≈ 1.2516) / 60 ± 2 HRC

Mat.: WAS** (≈ 1.2343) ≥ 950 HV_{0,3}

Mat.:

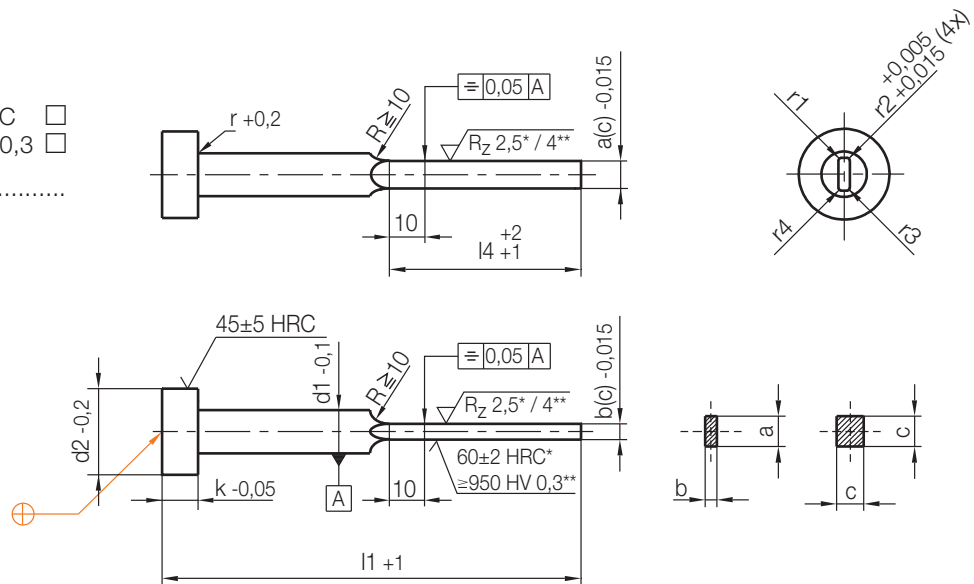

*** ≥ 0,15

keine Angabe = scharfkantig / not specified = sharp-edged / sans indication = à arêtes vives

Stck./ Pc.	Typ	d1	l1	a/c	b/c	l4	S	***				l1	a	b	c	l4 max.	d2	k	r
								r1	r2	r3	r4								
	Z 466 / 3	x	/	x	x	/ S					≥ 40	≥ 2	≥ 0,6	≥ 1,5	80	6	3	0,3	
	/ 3	x	/	x	x	/ S					↓	↓	↓						
	/ 3	x	/	x	x	/ S					≥ 250	≥ 2,5	≥ 1	≥ 2					
	Z 466 / 3,5	x	/	x	x	/ S					≥ 80	≥ 2	≥ 0,6	≥ 1,5		7			
	/ 3,5	x	/	x	x	/ S					↓	↓	↓						
	/ 3,5	x	/	x	x	/ S					≥ 250	≥ 3	≥ 1	≥ 2,3					
	Z 466 / 4	x	/	x	x	/ S					≥ 40	≥ 2,5	≥ 0,6	≥ 1,5	100	8			
	/ 4	x	/	x	x	/ S					↓	↓	↓						
	/ 4	x	/	x	x	/ S					≥ 400	≥ 3,5	≥ 1,2	≥ 2,7					
	Z 466 / 4,5	x	/	x	x	/ S					≥ 40	≥ 2,5	≥ 0,8	≥ 1,5					
	/ 4,5	x	/	x	x	/ S					↓	↓	↓						
	/ 4,5	x	/	x	x	/ S					≥ 315	≥ 4	≥ 1,2	≥ 3					
	Z 466 / 5	x	/	x	x	/ S					≥ 40	≥ 3	≥ 1	≥ 1,5		10			
	/ 5	x	/	x	x	/ S					↓	↓	↓						
	/ 5	x	/	x	x	/ S					≥ 400	≥ 4,5	≥ 1,3	≥ 3,4					
	Z 466 / 5,5	x	/	x	x	/ S					≥ 60	≥ 3	≥ 1	≥ 2					
	/ 5,5	x	/	x	x	/ S					↓	↓	↓						
	/ 5,5	x	/	x	x	/ S					≥ 315	≥ 5	≥ 1,3	≥ 3,7					
	Z 466 / 6	x	/	x	x	/ S					≥ 40	≥ 3	≥ 1	≥ 2,5	125	12	5	0,5	
	/ 6	x	/	x	x	/ S					↓	↓	↓						
	/ 6	x	/	x	x	/ S					≥ 400	≥ 5,5	≥ 1,3	≥ 4,1					
	Z 466 / 6,5	x	/	x	x	/ S					≥ 80	≥ 3	≥ 1,2	≥ 2,5					
	/ 6,5	x	/	x	x	/ S					↓	↓	↓						
	/ 6,5	x	/	x	x	/ S					≥ 315	≥ 6	≥ 2	≥ 4,4					
	Z 466 / 7	x	/	x	x	/ S					≥ 80	≥ 4	≥ 1,2	≥ 3					
	/ 7	x	/	x	x	/ S					↓	↓	↓						
	/ 7	x	/	x	x	/ S					≥ 315	≥ 6	≥ 2,5	≥ 4,8					

Bestellformular	Order form	Formulaire de commande
Firma / Company / Société: _____		
Zuständig / Contact / Responsable: _____		
Tel.: _____	Fax.: _____	Datum / Date: _____
<input type="checkbox"/> Bestellung / Order / Commande	Nr. / No.: _____	<input type="checkbox"/> Anfrage / Quotation / Demande

Z 466 / ... / S

Flachauswerfer
Flat ejector pin
Ejecteur lame

Mat.: WS* (≈ 1.2516) / 60 ± 2 HRC

Mat.: WAS** (≈ 1.2343) ≥ 950 HV 0,3

Mat.:

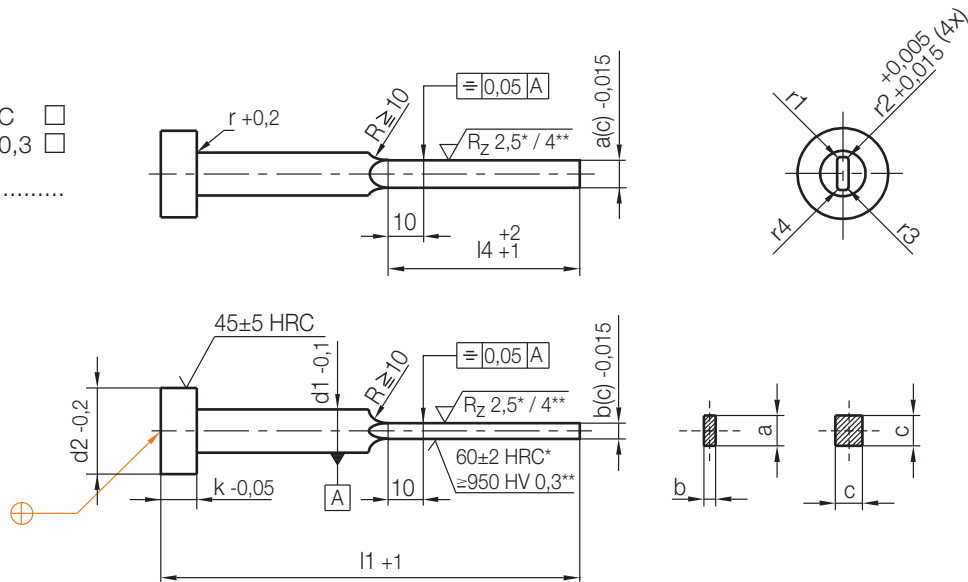

*** ≥ 0,15

keine Angabe = scharfkantig / not specified = sharp-edged / sans indication = à arêtes vives

Stck./ Pc.	Typ	d1	l1	a/c	b/c	l4	S	***				l1	a	b	c	l4 max.	d2	k	r
								r1	r2	r3	r4								
	Z 466 /	8 x	/	x	x	/ S						≥ 40	≥ 4	≥ 1,2	≥ 3	155	14	5	0,5
	/	8 x	/	x	x	/ S						↓	↓	↓	↓				
	/	8 x	/	x	x	/ S						≥ 400	≥ 7	≥ 3	≥ 5,5				
	Z 466 /	9 x	/	x	x	/ S						≥ 100	≥ 5	≥ 1,5	≥ 3,5				
	/	9 x	/	x	x	/ S						↓	↓	↓	↓				
	/	9 x	/	x	x	/ S						≥ 315	≥ 8	≥ 3	≥ 6,2				
	Z 466 /	10 x	/	x	x	/ S						≥ 60	≥ 5	≥ 1,5	≥ 3,5	200	16		
	/	10 x	/	x	x	/ S						↓	↓	↓	↓				
	/	10 x	/	x	x	/ S						≥ 400	≥ 9	≥ 3,5	≥ 7				
	Z 466 /	11 x	/	x	x	/ S						≥ 100	≥ 6	≥ 2	≥ 4				
	/	11 x	/	x	x	/ S						↓	↓	↓	↓				
	/	11 x	/	x	x	/ S						≥ 315	≥ 10	≥ 3,5	≥ 7,6				
	Z 466 /	12 x	/	x	x	/ S						≥ 80	≥ 6	≥ 2	≥ 4		18	7	0,8
	/	12 x	/	x	x	/ S						↓	↓	↓	↓				
	/	12 x	/	x	x	/ S						≥ 400	≥ 11	≥ 3,5	≥ 8,3				
	Z 466 /	14 x	/	x	x	/ S						≥ 100	≥ 7	≥ 2	≥ 5		22		
	/	14 x	/	x	x	/ S						↓	↓	↓	↓				
	/	14 x	/	x	x	/ S						≥ 400	≥ 13	≥ 4	≥ 9,7				
	Z 466 /	16 x	/	x	x	/ S						≥ 100	≥ 8	≥ 2	≥ 5				
	/	16 x	/	x	x	/ S						↓	↓	↓	↓				
	/	16 x	/	x	x	/ S						≥ 400	≥ 16	≥ 4	≥ 11,2				
	Z 466 /	18 x	/	x	x	/ S						≥ 160	≥ 9	≥ 3	≥ 6		24		
	/	18 x	/	x	x	/ S						↓	↓	↓	↓				
	/	18 x	/	x	x	/ S						≥ 315	≥ 17	≥ 4,5	≥ 12,6				
	Z 466 /	20 x	/	x	x	/ S						≥ 160	≥ 10	≥ 3	≥ 8		26	8	1
	/	20 x	/	x	x	/ S						↓	↓	↓	↓				
	/	20 x	/	x	x	/ S						≥ 400	≥ 19	≥ 5	≥ 14				

