

Z 456/...

Verschleißhülse
Wear sleeve
Douille d'usure

Mat.: WAS (≈ 1.2343)
gehärtet / hardened / trempé

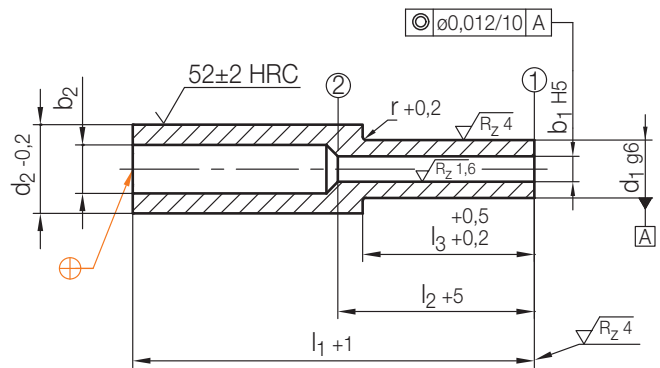
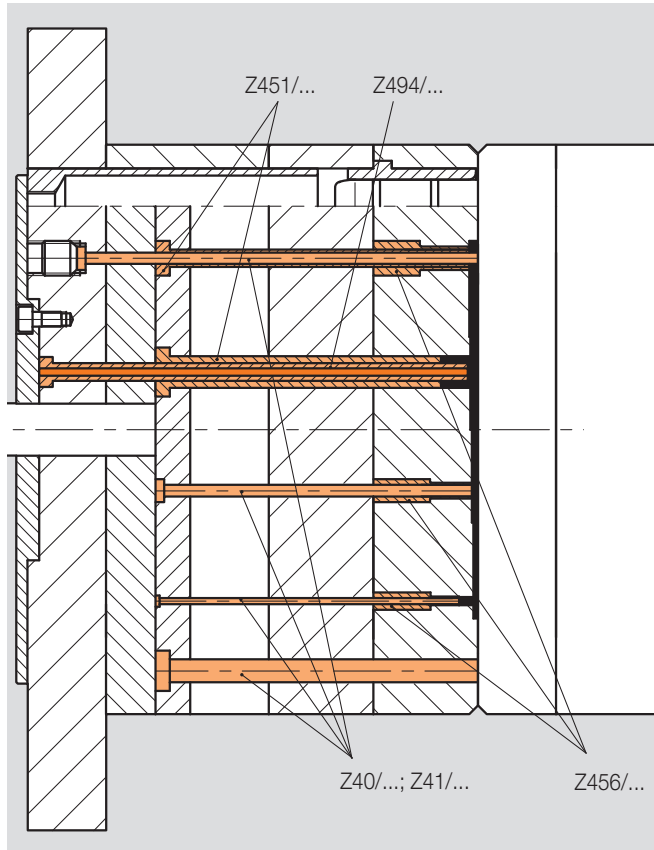
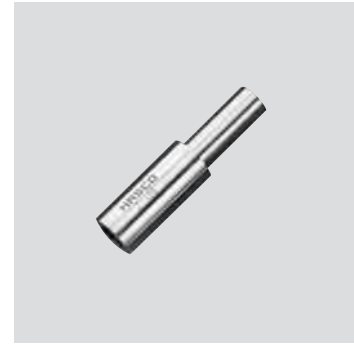

r	d ₂	b ₂	l ₂	l ₃	d ₁	b ₁	l ₁	Nr./No.
0,3	4	1,1	20	18	2	0,8	32	Z 456/2 /0,8x32
								1
		1,4			2,1	1,1	2,1/1,1x40	
		1,5			2,2	1,2	2,2/1,2x40	
		1,6			2,3	1,3	2,3/1,3x40	
		1,7			2,4	1,4	2,4/1,4x40	
		5			1,8	2,5	1,5	2,5/1,5x40
					1,9	2,6	1,6	2,6/1,6x40
	2		2,7	1,7	2,7/1,7x40			
	2,1		2,8	1,8	2,8/1,8x40			
	2,2		2,9	1,9	2,9/1,9x40			
	6		2,3	3	2	3 /2 x40		
			2,5	3,5	2,2	3,5/2,2x40		
			8	3	4	2,5	50	Z 456/4 /2,5x50
		3,5		4,5	3	4,5/3 x50		
	4	5		3,5	5 /3,5x50			
4,5	5,5	4		5,5/4 x50				

r	d ₂	b ₂	l ₂	l ₃	d ₁	b ₁	l ₁	Nr./No.	
0,5	10	5	25	22	6	4,5	50	Z456/ 6 / 4,5x 50	
		5,5			6,5	5		6,5/ 5 x 50	
0,5	12	6	32	27	7,5	5,5	63	Z456/ 7,5/ 5,5x 63	
		6,5			8	6		8 / 6 x 63	
		7			6,5	8 / 6,5x 63			
		7,5			9	7		9 / 7 x 63	
	14	8,5	10	8	10 / 8 x 63				
		9	8,5	10 / 8,5x 63					
		16	9,5	11	9	11 / 9 x 63			
			10,5	12	10	12 /10 x 63			
0,8	18	11	50	43	10,2	10,2	100	Z456/16 /12 x100	
		11,5			14	11		14 /11 x 63	
0,8	22	12,5	50	43	16	12	100	Z456/16 /12 x100	
	24	14,5			18	14		18 /14 x100	
	1	26			16,5	20		16	20 /16 x100
		30			20,5	24		20	24 /20 x100
		35			25,5	29		25	29 /25 x100