

Z4800 / ...

Beschriftungseinheit, eckig
 Marking unit, square
 Insert d'écriture, carré

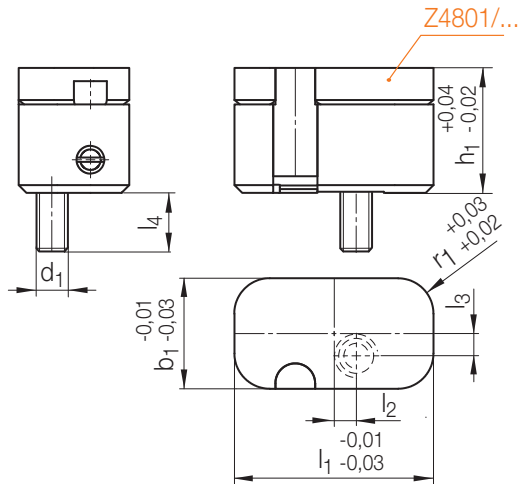

r ₁	l ₄	l ₃	l ₂	d ₁	h ₁	l ₁	b ₁	Nr./No.
3,2	5	2	2,5	M3	11,2	18	10	Z4800/18x10
3,5	4	4	4,5		12,7	25	20	25x20
		6,5	8			35	25	35x25

Z4801 / ...

Wechseleinsatz, eckig
 Interchangeable insert, square
 Insert interchangeable, carré

Mat.: 1.2767/53 + 2 HRC

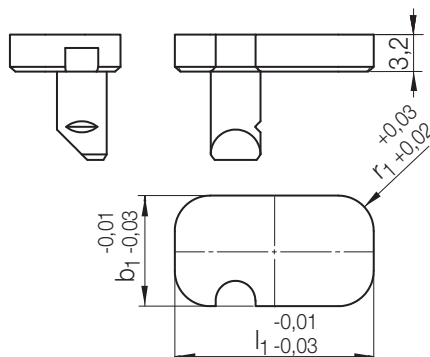

r ₁	l ₁	b ₁	Nr./No.
3,2	18	10	Z4801/18x10
3,5	25	20	25x20
	35	25	35x25

2

Z4810/...

Beschriftungseinheit, rund
 Marking unit, round
 Insert d'écriture, rond

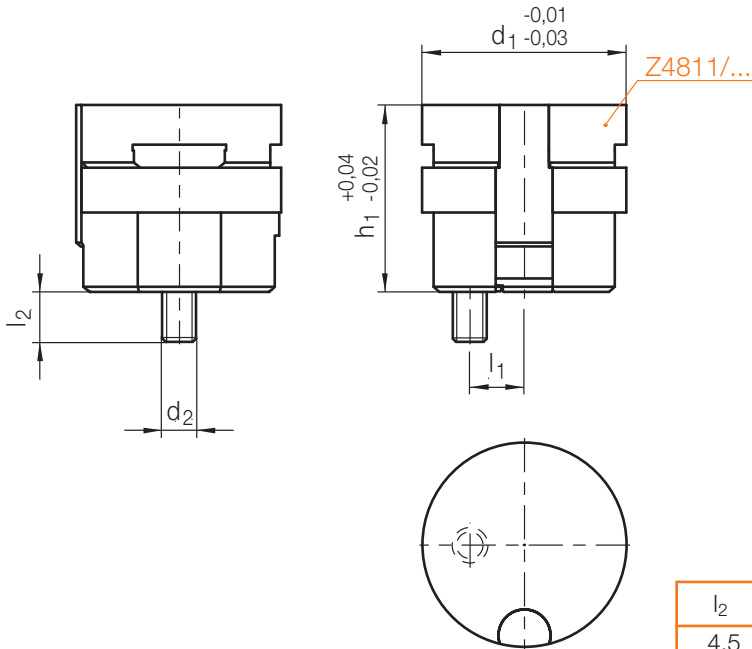

l_2	l_1	h_1	d_2	d_1	Nr./No.
4,5	4,8	16,5	M3	18	Z4810/18
7,5	7	18,5	M4	25	25
6	10	20		35	35

Z4811/...

Wechseleinsatz, rund
 Interchangeable insert, round
 Insert interchangeable, rond

Mat.: 1.2767/53 + 2 HRC

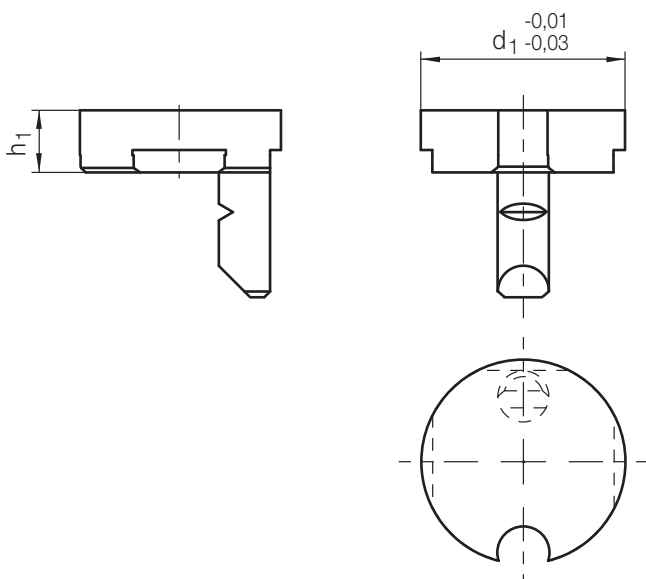

h_1	d_1	Nr./No.
5,5	18	Z4811/18
	25	25
	35	35

Z48/...

Datumsstempel
Date insert
Tampon-dateur
Mat.: 1.4112/58HRC

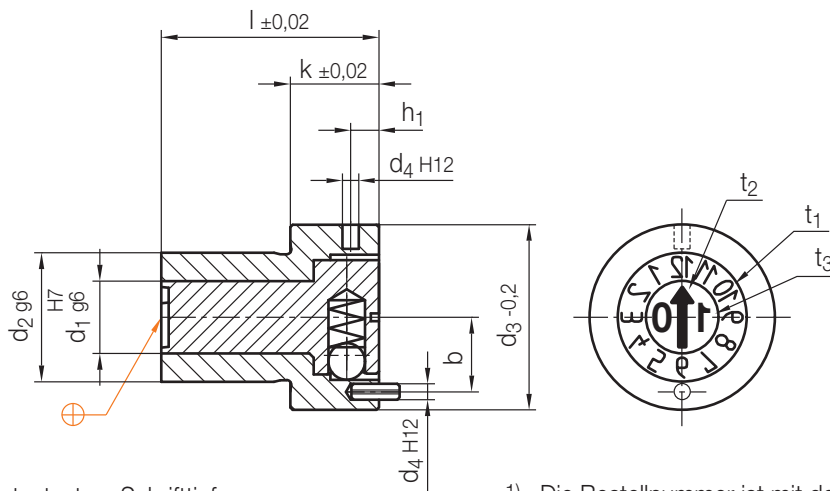

t₁, t₂, t₃ = Schrifftiefe
Depth of characters
Profondeur de la gravure

1) =Die Bestellnummer ist mit der Jahreszahl zu ergänzen
Please complete the order No. by specifying the required year
Le numéro de commande doit être complété avec le chiffre de l'année

t ₁	t ₂	t ₃	d ₄	h ₁	b	l	k	d ₃	d ₁	d ₂	Nr./No.1)
0,15	0,5	0,15	1,5	0,9	5	14	5	10	3,5	6	Z48/ 6/...
	6				17	6	12	4,5	8	8/...	
0,2	0,9	0,2	2	3,5	8	22	10	20	6,5	12	12/...
					9,25	27	11	23	9	16	16/...
					3	4	11,5	36	14	28	10,5

2

Z481/...

Jahres-Pfeileinsatz
Arrow-year insert
Insert flèche annuel
Mat.: 1.4112/58HRC

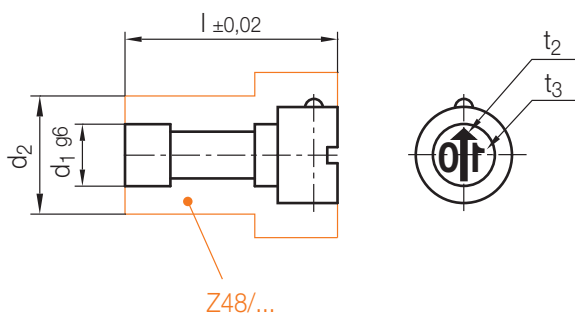

t₂, t₃ = Schrifftiefe
Depth of characters
Profondeur de la gravure

1) =Die Bestellnummer ist mit der Jahreszahl zu ergänzen
Please complete the order No. by specifying the required year
Le numéro de commande doit être complété avec le chiffre de l'année

t ₂	t ₃	l	d ₁	d ₂	Nr./No.1)
0,5	0,15	14	3,5	6	Z481/ 6/...
0,6		17	4,5	8	8/...
0,9	0,2	22	6,5	12	12/...

t ₂	t ₃	l	d ₁	d ₂	Nr./No.1)
0,9	0,2	27	9	16	Z481/16/...
		36	10,5	20	20/...

Z 482 / ...

Monats-Datumsstempel
 Month date insert
 Dateur Mois
 Mat.: 1.4112/58HRC

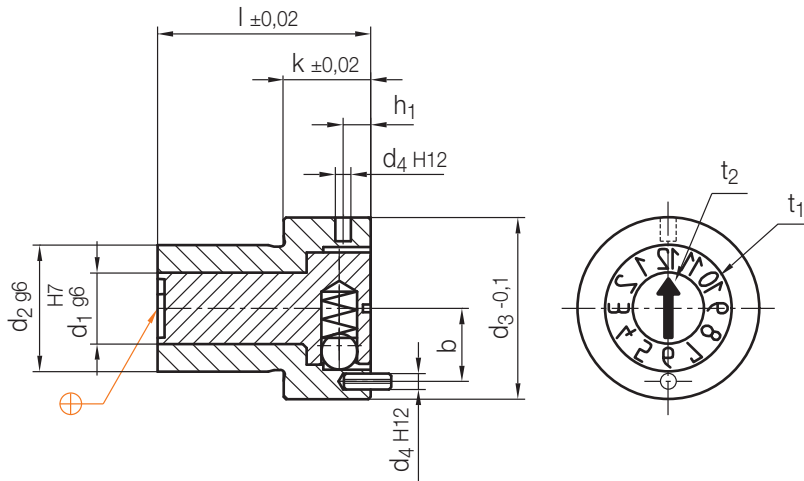

t₁, t₂ = Schrifttiefe
 Depth of characters
 Profondeur de la gravure

t ₁	t ₂	d ₄	h ₁	b	l	k	d ₃	d ₁	d ₂	Nr./No.
0,15	0,5	1,5	0,9	5	14	5	10	3,5	6	Z 482/ 6
	0,6			6	17	6	12	4,5	8	8
0,2	0,9	2	3,5	8	22	10	20	6,5	12	12

t ₁	t ₂	d ₄	h ₁	b	l	k	d ₃	d ₁	d ₂	Nr./No.
0,2	0,9	2	3,5	9,25	27	11	23	9	16	Z 482/16
		3	4	11,5	36	14	28	10,5	20	20

Z 483 / ...

Jahres-Datumsstempel
 Year-date insert
 Dateur Année
 Mat.: 1.4112/58HRC

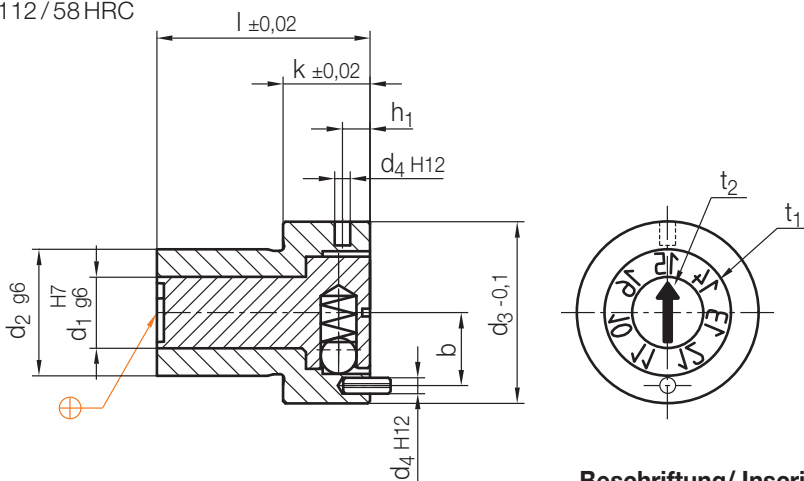

t₁, t₂ = Schrifttiefe
 Depth of characters
 Profondeur de la gravure

1) = Die Bestellnummer ist mit der Jahreszahl zu ergänzen.
 Please complete the order No. by specifying the required year.
 Le numéro de commande doit être complété avec le chiffre de l'année.

Beschriftung/ Inscription/ Inscription

Jeweils laufendes Jahr + 6 Jahre
 Current year + 6 following years
 A chaque fois l'année en cours + 6 ans

t ₁	t ₂	d ₄	h ₁	b	l	k	d ₃	d ₁	d ₂	Nr./No. ¹⁾
0,15	0,5	1,5	0,9	5	14	5	10	3,5	6	Z 483/ 6/...
	0,6			6	17	6	12	4,5	8	8/...
0,2	0,9	2	3,5	8	22	10	20	6,5	12	12/...

t ₁	t ₂	d ₄	h ₁	b	l	k	d ₃	d ₁	d ₂	Nr./No. ¹⁾
0,2	0,9	2	3,5	9,25	27	11	23	9	16	Z 483/16/...
		3	4	11,5	36	14	28	10,5	20	20/...

Z 484 / ...

Pfeileinsatz
 Arrow insert
 Insert flèche

Mat.: 1.4112/58HRC

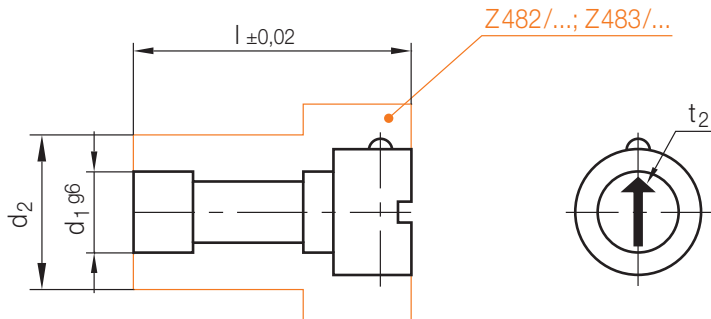

2

t_2 = Schrifttiefe
 Depth of characters
 Profondeur de la gravure

t_2	l	d_1	d_2	Nr./No.
0,5	14	3,5	6	Z484/ 6
0,6	17	4,5	8	8
0,9	22	6,5	12	12

t_2	l	d_1	d_2	Nr./No.
0,9	27	9	16	Z484/16
	36	10,5	20	20

Z 485/...

Datumsstempel
Date insert
Dateur

Mat.: 1.4112/58HRC

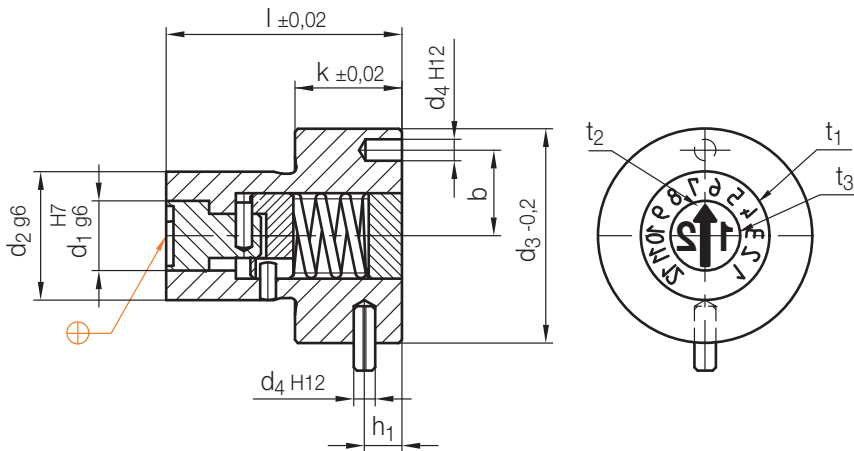

t₁, t₂, t₃ = Schrifttiefe
Depth of characters
Profondeur de la gravure

1) =Die Bestellnummer ist mit der Jahreszahl zu ergänzen
Please complete the order No. by specifying the required year
Le numéro de commande doit être complété avec le chiffre de l'année

t ₁	t ₂	t ₃	d ₄	h ₁	l	k	b	d ₃	d ₁	d ₂	Nr./No.1)
0,15	0,5	0,15	1,5	1,5	14	5	3,5	10	3,5	6	Z485/ 6/...
	0,6			17	6	4,5	12	4,5	8	8/...	
0,2	0,9	0,2	2	3,5	22	10	8	20	6,5	12	12/...
				3	27	11	9,25	23	9	16	16/...
				4	36	14	11,5	28	10,5	20	20/...

Z 4851/...

Jahres-Pfeileinsatz
Arrow insert
Insert flèche annuel

Mat.: 1.4112/58HRC

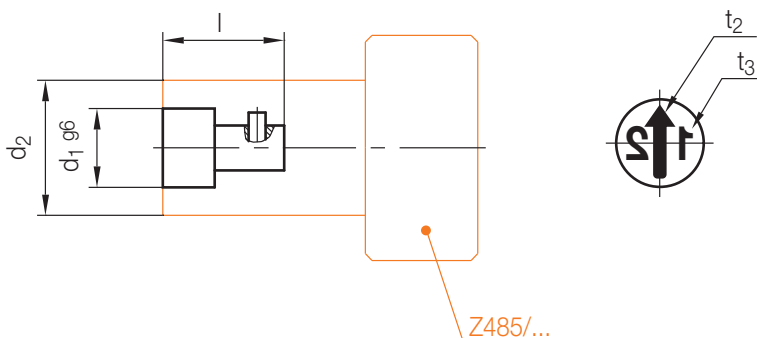
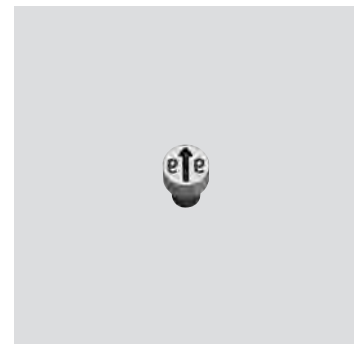

t₂, t₃ = Schrifttiefe
Depth of characters
Profondeur de la gravure

1) =Die Bestellnummer ist mit der Jahreszahl zu ergänzen
Please complete the order No. by specifying the required year
Le numéro de commande doit être complété avec le chiffre de l'année

t ₂	t ₃	l	d ₁	d ₂	Nr./No.1)	t ₂	t ₃	l	d ₁	d ₂	Nr./No.1)
0,5	0,15	5,2	3,5	6	Z4851/ 6/...	0,9	0,2	11,5	9	16	Z4851/16/...
0,6		7	4,5	8	8/...			15	10,5	20	20/...
0,9	0,2	8,85	6,5	12	12/...						

Z 48700/...

Jahr / Monats - Schriftstempel

Year / Month - marking insert

Dateur - Année / Mois

Mat.: 1.4112/58 HRC

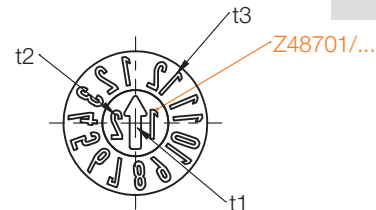
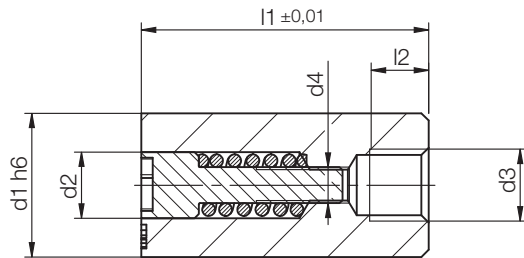

t1, t2, t3 = Schrifttiefe
Depth of characters
Profondeur de la gravure

1) =Die Bestellnummer ist mit der Jahreszahl zu ergänzen
Please complete the order No. by specifying the required year
Le numéro de commande doit être complété avec le chiffre de l'année

2

t3	t2	t1	l2	l1	d4	d3	d2	d1	Nr. / No. 1)
0,1	0,13	0,25	3	14	M 1,4x0,2	M2	2,5	4	Z 48700/ 4x... 1)
0,12	0,15	0,3	3,5	17	M 1,6x0,2	M3	3,1	5	5x... 1)
0,15								6	6x... 1)
0,18	0,2	0,5	4	20	M 2,5x0,35	M4	4,6	8	8x... 1)
0,2								10	10x... 1)
	0,25		6	25	M3 x0,5	M6	6,4	12	12x... 1)

Z 48701/...

Jahres-Pfeileinsatz

Arrow - year insert

Insert flèche annuel

Mat.: 1.4112/58 HRC

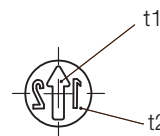
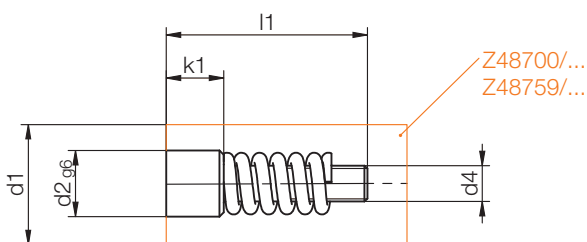

t1, t2 = Schrifttiefe
Depth of characters
Profondeur de la gravure

1) =Die Bestellnummer ist mit der Jahreszahl zu ergänzen
Please complete the order No. by specifying the required year
Le numéro de commande doit être complété avec le chiffre de l'année

t2	t1	k1	l1	d4	d2	d1	Nr. / No
0,13	0,25	2,3	10,5	M 1,4x0,2	2,5	4	Z 48701/ 4x... 1)
0,15	0,3	3	13	M 1,6x0,2	3,1	5	5x... 1)
						6	6x... 1)
0,2	0,5	4	14	M 2,5x0,35	4,6	8	8x... 1)
						10	10x... 1)
0,25			17	M3 x0,5	6,4	12	12x... 1)

Z 48705/...

Monats - Schriftstempel
 Month - marking insert
 Insert d'écriture mois
 Mat.: 1.4112/58 HRC

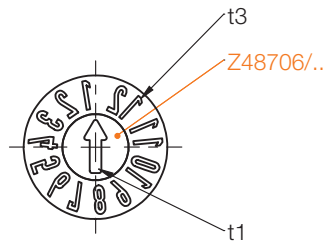
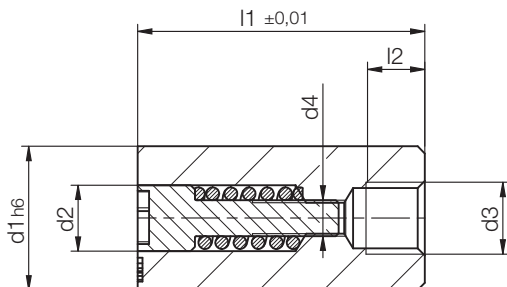

t1, t3 = Schrifttiefe
 Depth of characters
 Profondeur de la gravure

t3	t1	l2	l1	d4	d3	d2	d1	Nr./No
0,1	0,25	3	14	M 1,4x0,2	M2	2,5	4	Z 48705/ 4
0,12	0,3	3,5	17	M 1,6x0,2	M3	3,1	5	5
0,15							6	6
0,18							8	8
0,2	0,5	4	20	M 2,5x0,35	M4	4,6	10	10
							12	12
		6	25	M 3 x0,5	M6	6,4	12	12

Z 48706/...

Pfeileinsatz
 Arrow insert
 Insert flèche
 Mat.: 1.4112/58 HRC

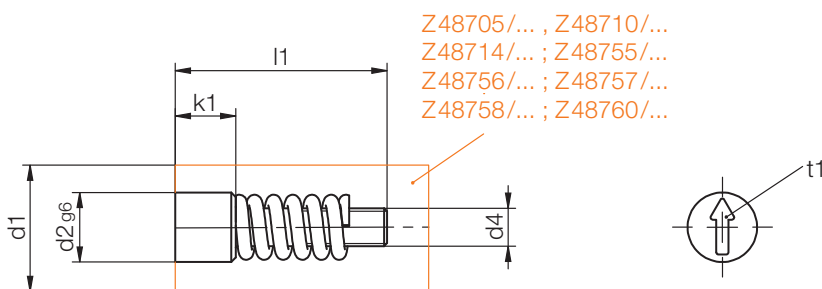

Z48705/... ; Z48710/...
 Z48714/... ; Z48755/...
 Z48756/... ; Z48757/...
 Z48758/... ; Z48760/...

t1 = Schrifttiefe
 Depth of characters
 Profondeur de la gravure

t1	k1	l1	d4	d2	d1	Nr./No
0,25	2,3	10,5	M 1,4x0,2	2,5	4	Z 48706/ 4
0,3	3	13	M 1,6x0,2	3,1	5	5
					6	6
					8	8
0,5	4	14	M 2,5x0,35	4,6	10	10
					12	12
				17	M 3 x0,5	6,4

Z48707 / ...

Jahr - / Wochen-Schriftstempel
 Year - / week-marking insert
 Dateur Année / Semaines

Mat.: 1.4112/58 HRC

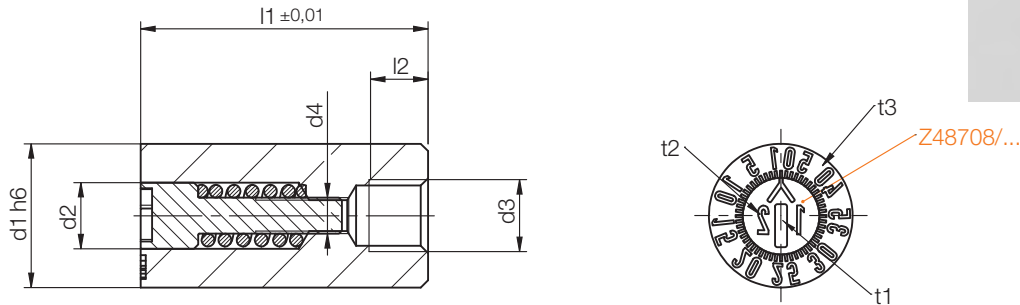

t1, t2, t3 = Schrifttiefe
 Depth of characters
 Profondeur de la gravure

1) =Die Bestellnummer ist mit der Jahreszahl zu ergänzen
 Please complete the order No. by specifying the required year
 Le numéro de commande doit être complété avec le chiffre de l'année

2

t3	t2	t1	l2	l1	d4	d3	d2	d1	Nr. / No. 1)
0,12	0,15	0,3	3,5	17	M1,6x0,2	M3	3,1	5	Z48707/ 5x... 1)
6								6x... 1)	
0,18	0,2	0,5	4	20	M2,5x0,35	M4	4,6	8	8x... 1)
10								10x... 1)	
12								12x... 1)	
0,2	0,25		6	25	M3 x0,5	M6	6,4		

Z48708 / ...

Jahres - Pfeileinsatz
 Arrow - year insert
 Insert flèche annuel

Mat.: 1.4112/58 HRC

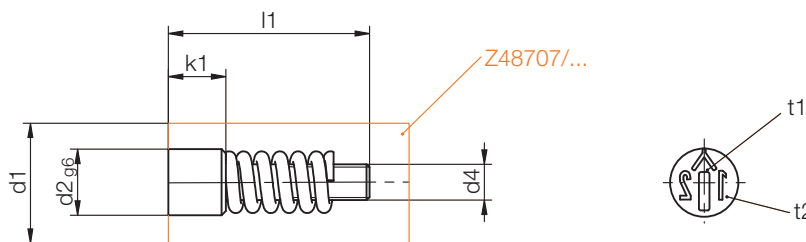
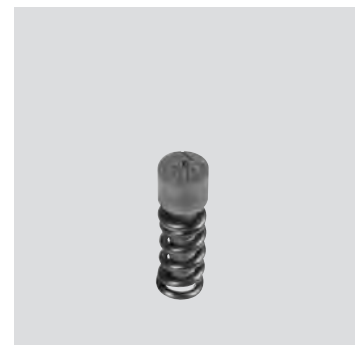

t1, t2 = Schrifttiefe
 Depth of characters
 Profondeur de la gravure

1) =Die Bestellnummer ist mit der Jahreszahl zu ergänzen
 Please complete the order No. by specifying the required year
 Le numéro de commande doit être complété avec le chiffre de l'année

t2	t1	k1	l1	d4	d2	d1	Nr. / No. 1)
0,15	0,3	3	13	M1,6x0,2	3,1	5	Z48708/ 5x... 1)
						6	6x... 1)
0,2	0,5	4	14	M2,5x0,35	4,6	8	8x... 1)
						10	10x... 1)
0,25			17	M3 x0,5	6,4	12	12x... 1)

Z48710/...

Jahres-Schriftstempel
Year-marking insert
Insert d'écriture année

Mat.: 1.4112/58 HRC

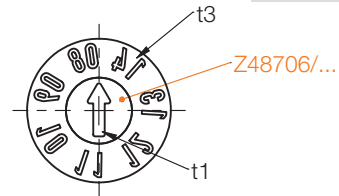
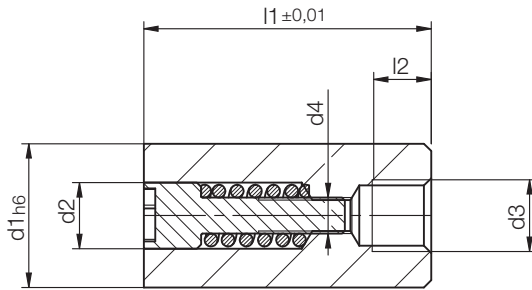

t1, t3 = Schrifttiefe
Depth of characters
Profondeur de la gravure

1) =Die Bestellnummer ist mit der Jahreszahl zu ergänzen
Please complete the order No. by specifying the required year
Le numéro de commande doit être complété avec le chiffre de l'année

t3	t1	l2	l1	d4	d3	d2	d1	Nr./No. 1)
0,1	0,25	3	14	M 1,4x0,2	M2	2,5	4	Z48710/ 4x... 1)
0,12	0,3	3,5	17	M 1,6x0,2	M3	3,1	5	5x... 1)
0,15							6	6x... 1)
0,18	0,5	4	20	M 2,5x0,35	M4	4,6	8	8x... 1)
0,2							10	10x... 1)
		6	25	M3 x0,5	M6	6,4	12	12x... 1)

Z48711/...

Wochen-Schriftstempel
Week-marking insert
Insert semaines

Mat.: 1.4112/58 HRC

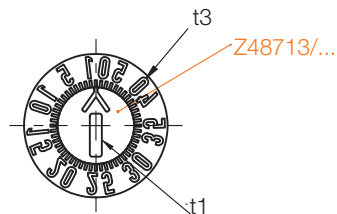
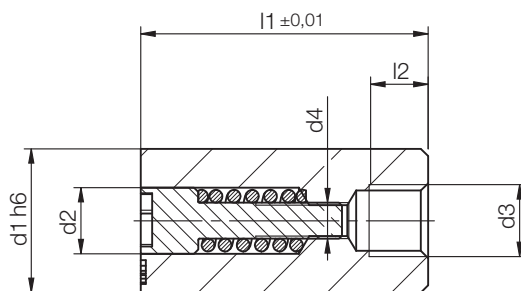

t1, t3 = Schrifttiefe
Depth of characters
Profondeur de la gravure

t3	t1	l2	l1	d4	d3	d2	d1	Nr./No.
0,12	0,3	3,5	17	M 1,6x0,2	M3	3,1	5	Z48711/5
0,15							6	6
0,18	0,5	4	20	M 2,5x0,35	M4	4,6	8	8
0,2							10	10
		6	25	M3 x0,5	M6	6,4	12	12

Z48712/...

Tages - Schriftstempel
 Day - marking insert
 Insert flèche jour
 Mat.: 1.4112/58 HRC

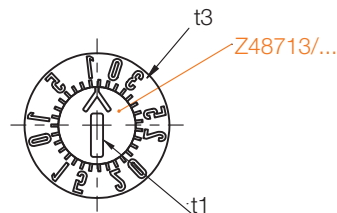
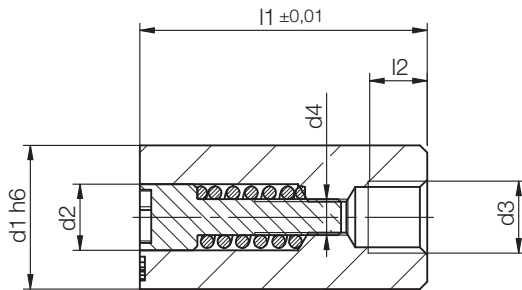
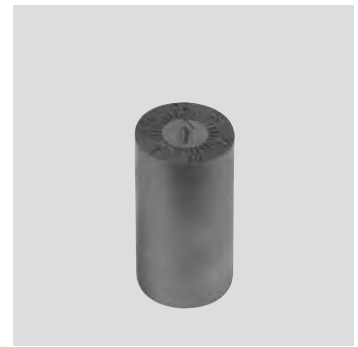

t1, t3 = Schrifttiefe
 Depth of characters
 Profondeur de la gravure

2

t3	t1	l2	l1	d4	d3	d2	d1	Nr./No.
0,12	0,3	3,5	17	M 1,6x0,2	M3	3,1	5	Z48712/5
0,15							6	6
0,18	0,5	4	20	M 2,5x0,35	M4	4,6	8	8
0,2							10	10
		6	25	M 3 x0,5	M6	6,4	12	12

Z48713/...

Pfeileinsatz
 Arrow insert
 Insert flèche
 Mat.: 1.4112/58 HRC

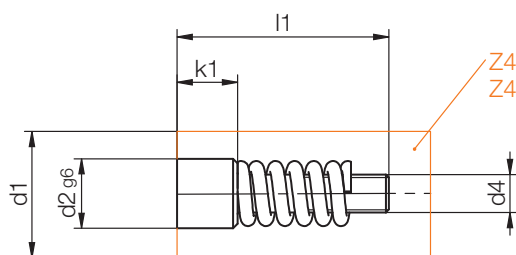
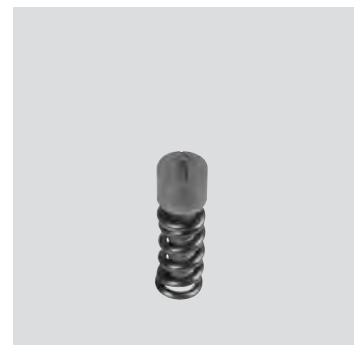

Z48711/...
 Z48712/...

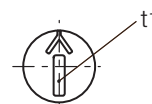

t1 = Schrifttiefe
 Depth of characters
 Profondeur de la gravure

t1	k1	l1	d4	d2	d1	Nr./No
0,3	3	13	M 1,6x0,2	3,1	5	Z48713/ 5
					6	6
0,5	4	14	M 2,5x0,35	4,6	8	8
					10	10
		17	M 3 x0,5	6,4	12	12

Z48714/...

Wochentage - Schriftstempel
 Weekday - marking insert
 Dateur journalier

Mat.: 1.4112/58 HRC

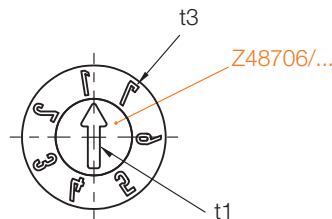
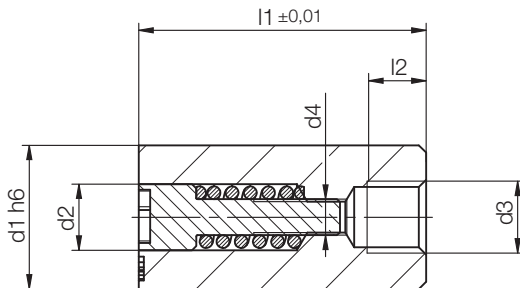

t1, t3 = Schrifttiefe
 Depth of characters
 Profondeur de la gravure

t3	t1	l2	l1	d4	d3	d2	d1	Nr./No
0,1	0,25	3	14	M1,4x0,2	M2	2,5	4	Z48714/ 4
0,12	0,3	3,5	17	M1,6x0,2	M3	3,1	5	5
0,15							6	6
0,18	0,5	4	20	M2,5x0,35	M4	4,6	8	8
0,2							M5	10
					6	25	M3,0x0,5	M6

Z48755/...

Schicht Schriftstempel
 Shift marking insert
 Insert d'indication d'équipe

Mat.: 1.4112/58 HRC

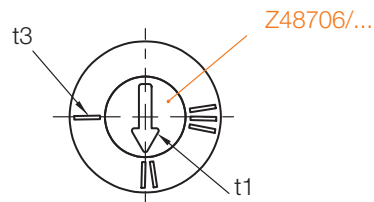
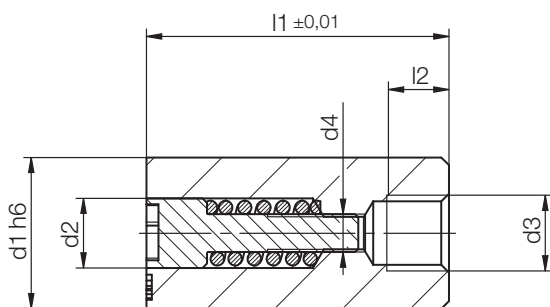

t1, t3 = Schrifttiefe
 Depth of characters
 Profondeur de la gravure

t3	t1	l2	l1	d4	d3	d2	d1	Nr./No
0,1	0,25	3	14	M1,4x0,2	M2	2,5	4	Z48755/ 4
0,12	0,3	3,5	17	M1,6x0,2	M3	3,1	5	5
0,15							6	6
0,18	0,5	4	20	M2,5x0,35	M4	4,6	8	8
0,2							M5	10
					6	25	M3 x0,5	M6

Z48756/...

A - M - Schriftstempel
 A - M - Marking insert
 Insert d'écriture A - M
 Mat.: 1.4112/58 HRC

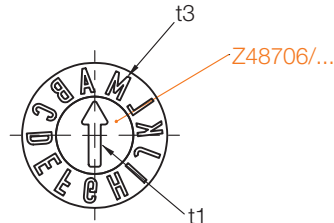
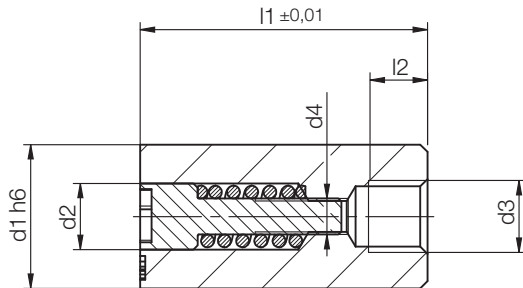

t1, t3 = Schrifttiefe
 Depth of characters
 Profondeur de la gravure

t3	t1	l2	l1	d4	d3	d2	d1	Nr. / No
0,1	0,25	3	14	M 1,4x0,2	M2	2,5	4	Z48756/ 4
0,12	0,3	3,5	17	M 1,6x0,2	M3	3,1	5	5
0,15							6	6
0,18	0,5	4	20	M 2,5x0,35	M4	4,6	8	8
0,2							10	10
		6	25	M 3 x0,5	M6	6,4	12	12

2

Z48757/...

N - Z - Schriftstempel
 N - Z - Marking insert
 Insert d'écriture N - Z
 Mat.: 1.4112/58 HRC

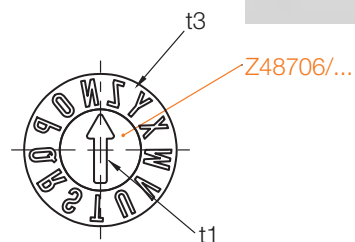
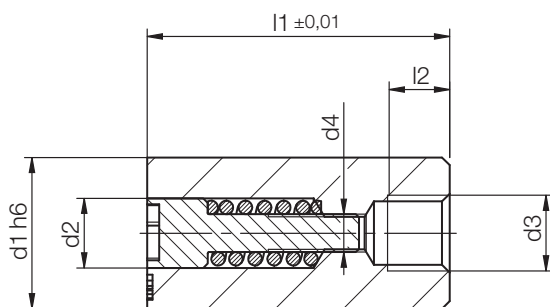

t1, t3 = Schrifttiefe
 Depth of characters
 Profondeur de la gravure

t3	t1	l2	l1	d4	d3	d2	d1	Nr. / No
0,1	0,25	3	14	M 1,4x0,2	M2	2,5	4	Z48757/ 4
0,12	0,3	3,5	17	M 1,6x0,2	M3	3,1	5	5
0,15							6	6
0,18	0,5	4	20	M 2,5x0,35	M4	4,6	8	8
0,2							10	10
		6	25	M 3 x0,5	M6	6,4	12	12

Z48758/...

0-9 - Schriftstempel
 0-9 - Marking insert
 Insert d'écriture 0-9
 Mat.: 1.4112/58 HRC

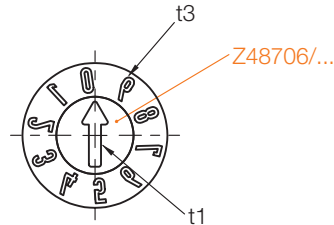
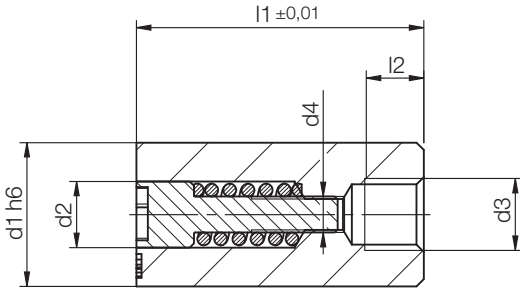

t1, t3 = Schrifttiefe
 Depth of characters
 Profondeur de la gravure

t3	t1	l2	l1	d4	d3	d2	d1	Nr./No
0,1	0,25	3	14	M 1,4x0,2	M2	2,5	4	Z48758/ 4
0,12	0,3	3,5	17	M 1,6x0,2	M3	3,1	5	5
0,15							6	6
0,18	0,5	4	20	M 2,5x0,35	M4	4,6	8	8
0,2							10	10
		6	25	M3 x0,5	M6	6,4	12	12

Z48759/...

Jahr / Quartal - Schriftstempel
 Year -/quarter -marking insert
 Dateur Année / Trimestre
 Mat.: 1.4112/58 HRC

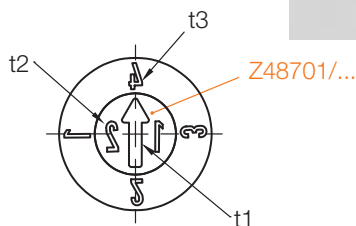
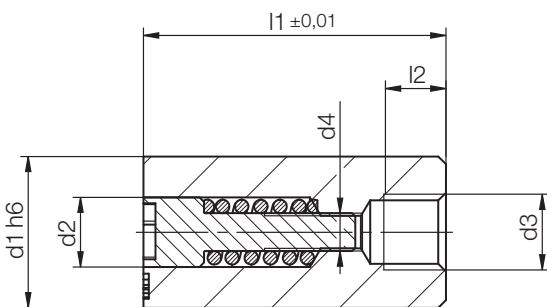

t1, t2, t3 = Schrifttiefe
 Depth of characters
 Profondeur de la gravure

1) =Die Bestellnummer ist mit der Jahreszahl zu ergänzen
 Please complete the order No. by specifying the required year
 Le numéro de commande doit être complété avec le chiffre de l'année

t3	t2	t1	l2	l1	d4	d3	d2	d1	Nr./No. 1)
0,1	0,13	0,25	3	14	M 1,4x0,2	M2	2,5	4	Z48759/ 4x... 1)
0,12	0,15	0,3	3,5	17	M 1,6x0,2	M3	3,1	5	5x... 1)
0,15								6	6x... 1)
0,18	0,2	0,5	4	20	M 2,5x0,35	M4	4,6	8	8x... 1)
0,2								10	10x... 1)
	0,25		6	25	M3 x0,5	M6	6,4	12	12x... 1)

Z 48760/...

Quartal - Schriftstempel
 Quarter - marking insert
 Insert trimestre

Mat.: 1.4112/58 HRC

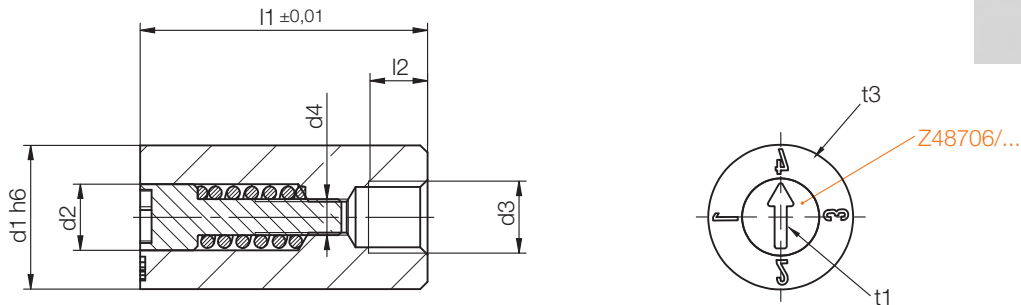

t1, t3 = Schrifttiefe
 Depth of characters
 Profondeur de la gravure

2

t3	t1	l2	l1	d4	d3	d2	d1	Nr./No
0,1	0,25	3	14	M 1,4x0,2	M2	2,5	4	Z 48760/ 4
0,12	0,3	3,5	17	M 1,6x0,2	M3	3,1	5	5
0,15							6	6
0,18	0,5	4	20	M 2,5x0,35	M4	4,6	8	8
0,2							M5	10
					6	25	M3 x0,5	M6

Z 48715/...

Jahr / Monats - Schriftstempel
 Year / Month - marking insert
 Dateur - Année / Mois

Mat.: 1.4112/58 HRC

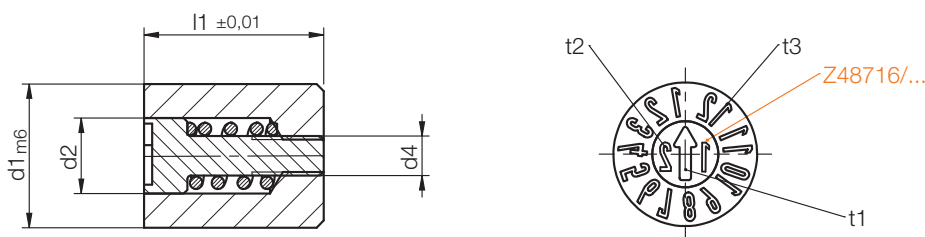
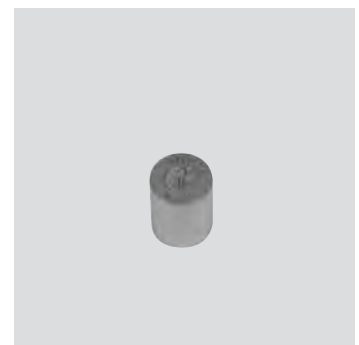

t1, t2, t3 = Schrifttiefe
 Depth of characters
 Profondeur de la gravure

1) =Die Bestellnummer ist mit der Jahreszahl zu ergänzen
 Please complete the order No. by specifying the required year
 Le numéro de commande doit être complété avec le chiffre de l'année

t3	t2	t1	l1	d4	d2	d1	Nr./No. 1)
0,09	0,1	0,18	4	M 0,8x0,2	1,4	2,6	Z 48715/2,6 x... 1)
0,1					1,5	3	3 x... 1)
0,11	0,11	0,22	5	M 1,1x0,25	2,1	4	4 x... 1)
0,15	0,15	0,3	8	M 1,6x0,2	3,1	5	5 x... 1)
						6	6 x... 1)
0,2	0,2	0,45	10	M 2,3x0,25	4,4	8	8 x... 1)
			12	M 2,5x0,35	5,2	10	10 x... 1)
0,25	0,25		14	M 3 x0,35	6,2	12	12 x... 1)

Z 48716/...

Jahres - Pfeileinsatz
 Arrow - year insert
 Insert flèche annuel

Mat.: 1.4112/58 HRC

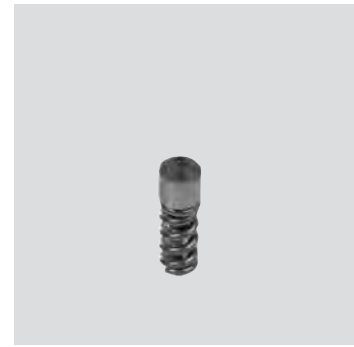
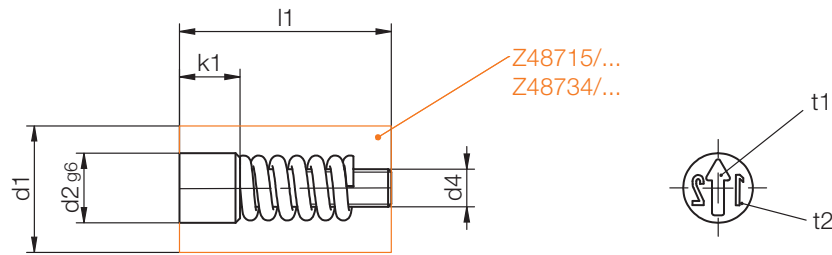

t1, t2 = Schrifttiefe
 Depth of characters
 Profondeur de la gravure

1) =Die Bestellnummer ist mit der Jahreszahl zu ergänzen
 Please complete the order No. by specifying the required year
 Le numéro de commande doit être complété avec le chiffre de l'année

t2	t1	k1	l1	d4	d2	d1	Nr./No. 1)
0,1	0,18	1	4	M0,8x0,2	1,4	2,6	Z48716/ 2,6x... 1)
					1,5	3	3 x... 1)
0,11	0,22	1,2	5	M1,1x0,25	2,1	4	4 x... 1)
0,15	0,3	2	8	M1,6x0,2	3,1	5	5 x... 1)
						6	6 x... 1)
0,2	0,45	2,5	10	M2,3x0,25	4,4	8	8 x... 1)
		3	12	M2,5x0,35	5,2	10	10 x... 1)
0,25			14	M3 x0,35	6,2	12	12 x... 1)

Z 48717/...

Monats - Schriftstempel
 Month - marking insert
 Insert d'écriture mois

Mat.: 1.4112/58 HRC

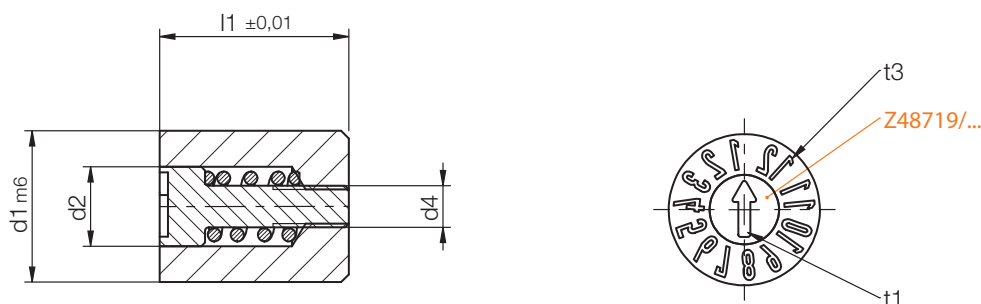

t1, t3 = Schrifttiefe
 Depth of characters
 Profondeur de la gravure

t3	t1	l1	d4	d2	d1	Nr./No. 1)
0,09	0,18	4	M0,8x0,2	1,4	2,6	Z48717/2,6
				1,5	3	3
0,11	0,22	5	M1,1x0,25	2,1	4	4
0,15	0,3	8	M1,6x0,2	3,1	5	5
					6	6
0,2	0,45	10	M2,3x0,25	4,4	8	8
		12	M2,5x0,35	5,2	10	10
0,25		14	M3 x0,35	6,2	12	12

Z48718/...

Jahres-Schriftstempel
 Year-marking insert
 Insert d'écriture année
 Mat.: 1.4112/58 HRC

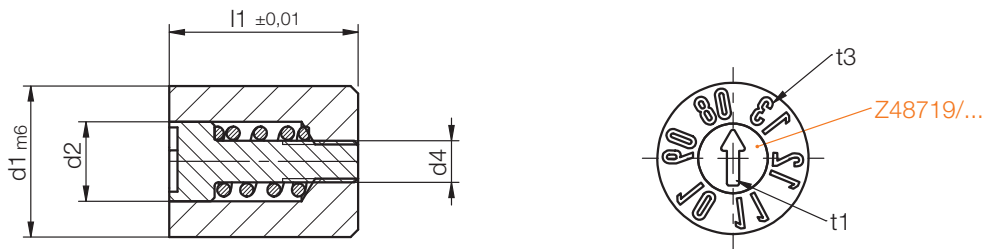
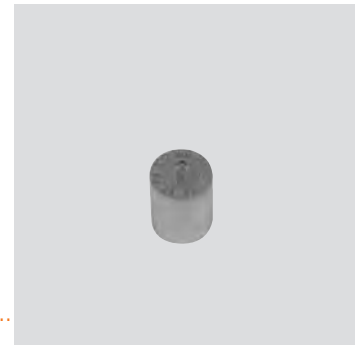

t1, t3 = Schrifttiefe
 Depth of characters
 Profondeur de la gravure

1) =Die Bestellnummer ist mit der Jahreszahl zu ergänzen
 Please complete the order No. by specifying the required year
 Le numéro de commande doit être complété avec le chiffre de l'année

2

t3	t1	l1	d4	d2	d1	Nr./No. 1)
0,09	0,18	4	M0,8x0,2	1,4	2,6	Z48718/2,6x... 1)
0,1				1,5	3	3 x... 1)
0,11	0,22	5	M1,1x0,25	2,1	4	4 x... 1)
0,15	0,3	8	M1,6x0,2	3,1	5	5 x... 1)
					6	6 x... 1)
0,2	0,45	10	M2,3x0,25	4,4	8	8 x... 1)
		12	M2,5x0,35	5,2	10	10 x... 1)
0,25		14	M3 x0,35	6,2	12	12 x... 1)

Z48719/...

Pfeileinsatz
 Arrow insert
 Insert flèche
 Mat.: 1.4112/58 HRC

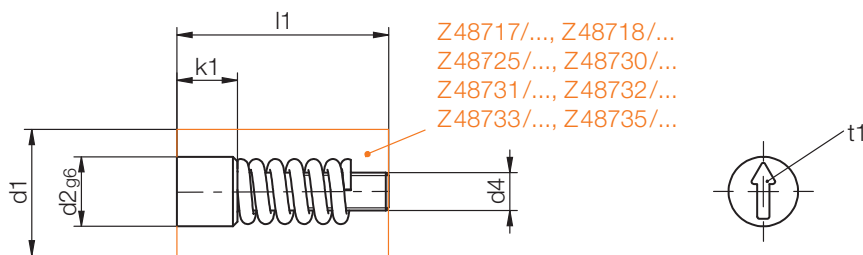
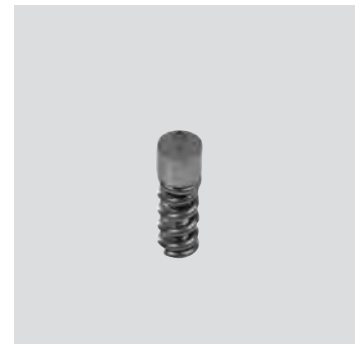

t1 = Schrifttiefe
 Depth of characters
 Profondeur de la gravure

t1	k1	l1	d4	d2	d1	Nr./No
0,18	1	4	M0,8x0,2	1,4	2,6	Z48719/ 2,6
				1,5	3	3
0,22	1,2	5	M1,1x0,25	2,1	4	4
0,3	2	8	M1,6x0,2	3,1	5	5
					6	6
0,45	2,5	10	M2,3x0,25	4,4	8	8
	3	12	M2,5x0,35	5,2	10	10
		14	M3 x0,35	6,2	12	12

Z 48720/...

Jahr / Wochen-Schriftstempel
 Year / Week-marking insert
 Dateur – Année / Semaines
 Mat.: 1.4112 / 58 HRC

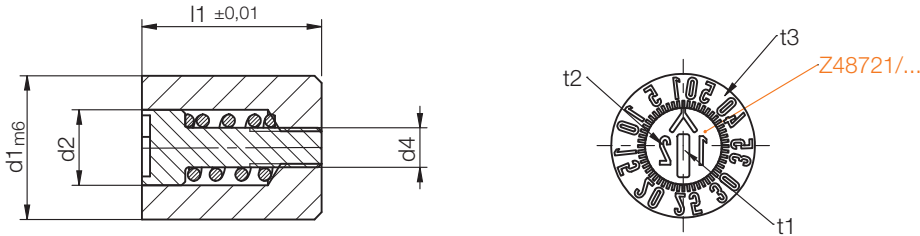
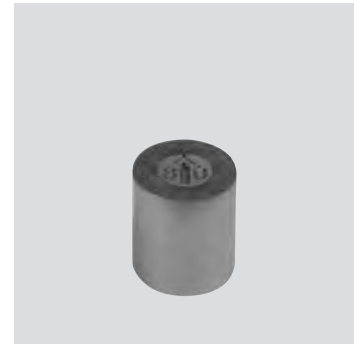

t1, t2, t3 = Schrifttiefe
 Depth of characters
 Profondeur de la gravure

1) =Die Bestellnummer ist mit der Jahreszahl zu ergänzen
 Please complete the order No. by specifying the required year
 Le numéro de commande doit être complété avec le chiffre de l'année

t3	t2	t1	l1	d4	d2	d1	Nr./No. 1)
0,15	0,15	0,3	8	M 1,6x0,2	3,1	5	Z 48720/5 x... 1)
						6	6 x... 1)
0,2	0,2	0,45	10	M 2,3x0,25	4,4	8	8 x... 1)
			12	M 2,5x0,35	5,2	10	10 x... 1)
0,25	0,25		14	M 3 x0,35	6,2	12	12 x... 1)

Z 48721/...

Jahres - Pfeileinsatz
 Arrow - year insert
 Insert flèche annuel
 Mat.: 1.4112 / 58 HRC

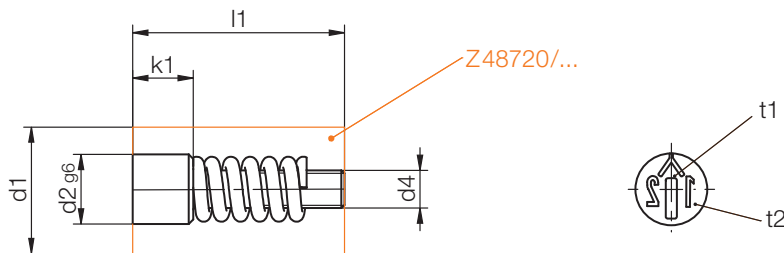
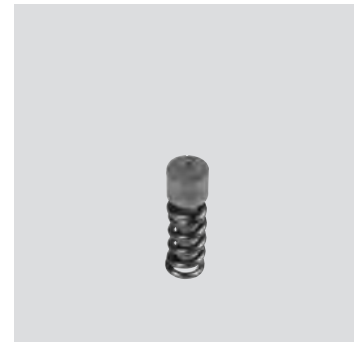

t1, t2 = Schrifttiefe
 Depth of characters
 Profondeur de la gravure

1) =Die Bestellnummer ist mit der Jahreszahl zu ergänzen
 Please complete the order No. by specifying the required year
 Le numéro de commande doit être complété avec le chiffre de l'année

t2	t1	k1	l1	d4	d2	d1	Nr./No
0,15	0,3	2	8	M 1,6x0,2	3,1	5	Z 48721/ 5 x... 1)
						6	6 x... 1)
0,2	0,45	2,5	10	M 2,3x0,25	4,4	8	8 x... 1)
		3	12	M 2,5x0,35	5,2	10	10 x... 1)
0,25			14	M 3 x0,35	6,2	12	12 x... 1)

Z48722/...

Wochen - Schriftstempel
 Week - marking insert
 Insert semaines
 Mat.: 1.4112/58 HRC

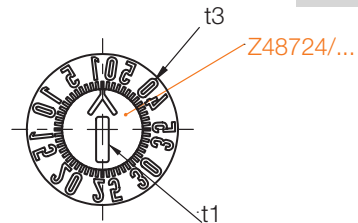
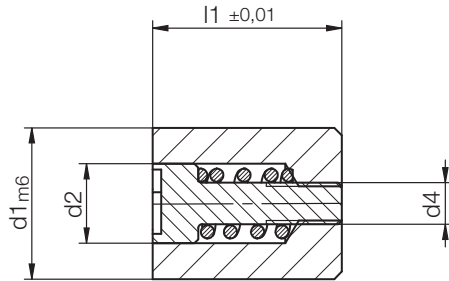

t1, t3 = Schrifttiefe
 Depth of characters
 Profondeur de la gravure

2

t3	t1	l1	d4	d2	d1	Nr./No. 1)
0,15	0,3	8	M1,6x0,2	3,1	5	Z48722/ 5
					6	6
0,2	0,45	10	M2,3x0,25	4,4	8	8
		12	M2,5x0,35	5,2	10	10
		14	M3 x0,35	6,2	12	12
0,25						

Z48723/...

Tages - Schriftstempel
 Day - marking insert
 Insert flèche jour
 Mat.: 1.4112/58 HRC

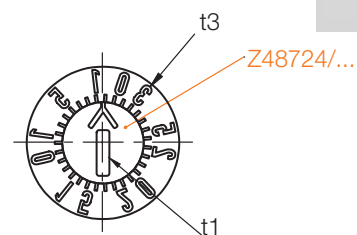
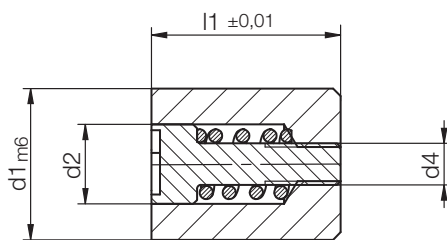

t1, t3 = Schrifttiefe
 Depth of characters
 Profondeur de la gravure

t3	t1	l1	d4	d2	d1	Nr./No.
0,15	0,3	8	M1,6x0,2	3,1	5	Z48723/ 5
					6	6
0,2	0,45	10	M2,3x0,25	4,4	8	8
		12	M2,5x0,35	5,2	10	10
		14	M3 x0,35	6,2	12	12
0,25						

Z48724/...

Pfeileinsatz
Arrow insert
Insert flèche
Mat.: 1.4112/58 HRC

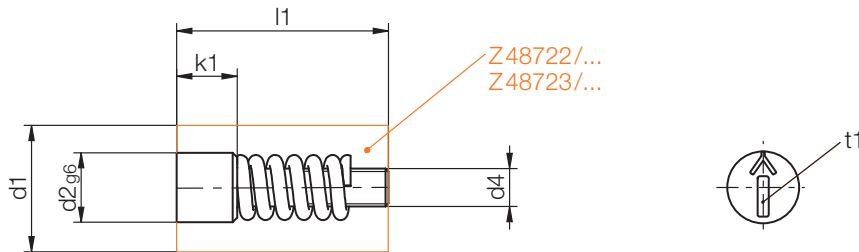
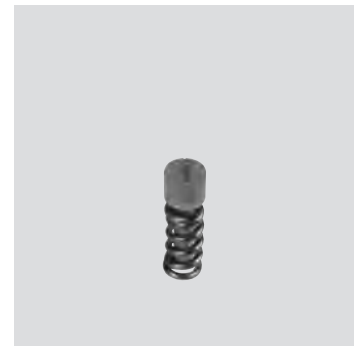

t1 = Schrifttiefe
Depth of characters
Profondeur de la gravure

t1	k1	l1	d4	d2	d1	Nr./No
0,3	2	8	M 1,6x0,2	3,1	5	Z48724/ 5
					6	6
0,45	2,5	10	M 2,3x0,25	4,4	8	8
		12	M 2,5x0,35	5,2	10	10
		14	M 3 x0,35	6,2	12	12

Z48725/...

Wochentage - Schriftstempel
Weekday - marking insert
Dateur journalier
Mat.: 1.4112/58 HRC

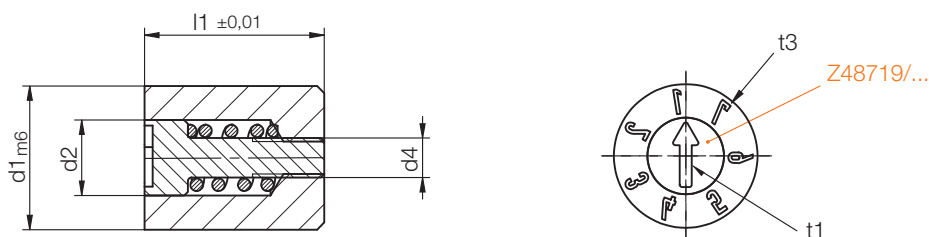

t1, t3 = Schrifttiefe
Depth of characters
Profondeur de la gravure

t3	t1	l1	d4	d2	d1	Nr./No.
0,09	0,18	4	M 0,8x0,2	1,4	2,6	Z48725/2,6
0,1				1,5	3	3
0,11	0,22	5	M 1,1x0,25	2,1	4	4
0,15	0,3	8	M 1,6x0,2	3,1	5	5
					6	6
0,2	0,45	10	M 2,3x0,25	4,4	8	8
		12	M 2,5x0,35	5,2	10	10
0,25		14	M 3 x0,35	6,2	12	12

Z48730 / ...

Schicht Schriftstempel
Shift marking insert
Insert d'indication d'équipe

Mat.: 1.4112/58 HRC

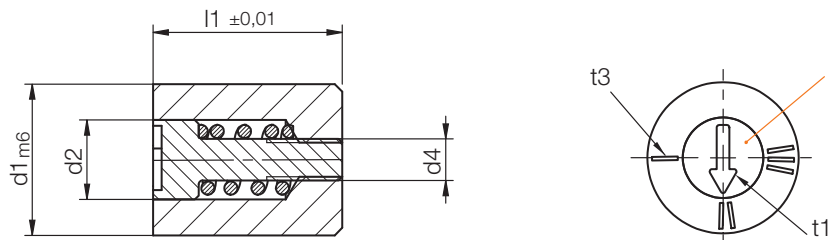

t1, t3 = Schrifttiefe
Depth of characters
Profondeur de la gravure

2

t3	t1	l1	d4	d2	d1	Nr./No. 1)
0,09	0,18	4	M0,8x0,2	1,4	2,6	Z48730/2,6
0,1				1,5	3	3
0,11	0,22	5	M1,1x0,25	2,1	4	4
0,15				3,1	5	5
					6	6
0,2	0,45	10	M2,3x0,25	4,4	8	8
		12	M2,5x0,35	5,2	10	10
0,25		14	M3 x0,35	6,2	12	12

Z48731 / ...

A-M-Schriftstempel
A-M Marking insert
Insert d'écriture A-M

Mat.: 1.4112/58 HRC

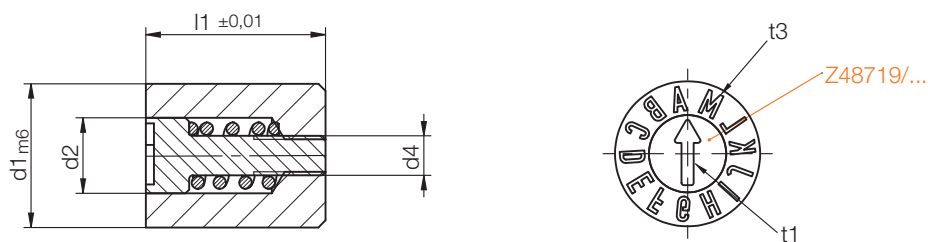

t1, t3 = Schrifttiefe
Depth of characters
Profondeur de la gravure

t3	t1	l1	d4	d2	d1	Nr./No. 1)
0,1	0,18	4	M0,8x0,2	1,5	3	Z48731/3
0,11				2,1	4	4
0,15	0,3	8	M1,6x0,2	3,1	5	5
					6	6
0,2	0,45	10	M2,3x0,25	4,4	8	8
		12	M2,5x0,35	5,2	10	10
0,25		14	M3 x0,35	6,2	12	12

Z 48732/...

N-Z - Schriftstempel
 N-Z Marking insert
 Insert d'écriture N-Z
 Mat.: 1.4112/58 HRC

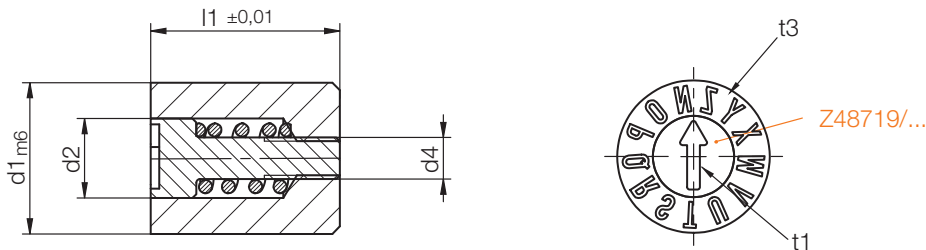

t1, t3 = Schrifttiefe
 Depth of characters
 Profondeur de la gravure

t3	t1	l1	d4	d2	d1	Nr./No.
0,1	0,18	4	M0,8x0,2	1,5	3	Z48732/3
0,11	0,22	5	M1,1x0,25	2,1	4	4
0,15	0,3	8	M1,6x0,2	3,1	5	5
					6	6
0,2	0,45	10	M2,3x0,25	4,4	8	8
		12	M2,5x0,35	5,2	10	10
0,25		14	M3 x0,35	6,2	12	12

Z 48733/...

0-9 - Schriftstempel
 0-9 Marking insert
 Insert d'écriture 0-9
 Mat.: 1.4112/58 HRC

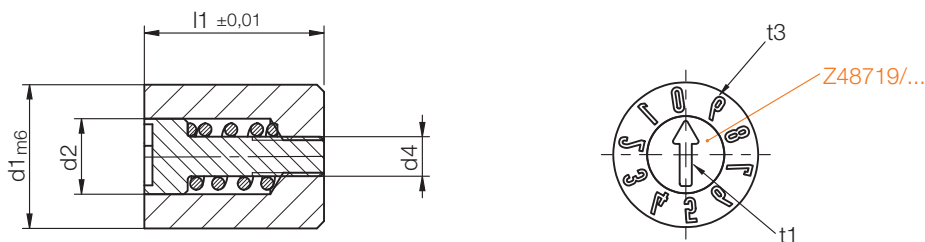

t1, t3 = Schrifttiefe
 Depth of characters
 Profondeur de la gravure

t3	t1	l1	d4	d2	d1	Nr./No.
0,09	0,18	4	M0,8x0,2	1,4	2,6	Z48733/2,6
0,1				1,5	3	3
0,11	0,22	5	M1,1x0,25	2,1	4	4
0,15	0,3	8	M1,6x0,2	3,1	5	5
					6	6
0,2	0,45	10	M2,3x0,25	4,4	8	8
		12	M2,5x0,35	5,2	10	10
0,25		14	M3 x0,35	6,2	12	12

Z 48734 / ...

Jahr / Quartal - Schriftstempel
 Year - / quarter - marking insert
 Dateur Année / Trimestre

Mat.: 1.4112/58 HRC

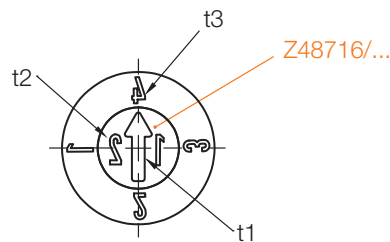
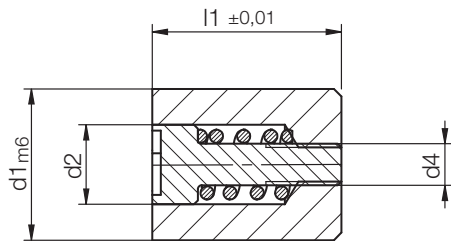

2

t1, t2, t3 = Schrifttiefe
 Depth of characters
 Profondeur de la gravure

1) =Die Bestellnummer ist mit der Jahreszahl zu ergänzen
 Please complete the order No. by specifying the required year
 Le numéro de commande doit être complété avec le chiffre de l'année

t3	t2	t1	l1	d4	d2	d1	Nr. / No. 1)
0,09	0,1	0,18	4	M 0,8x0,2	1,4	2,6	Z 48734 / 2,6 x... 1)
0,1					1,5	3	3 x... 1)
0,11	0,11	0,22	5	M 1,1x0,25	2,1	4	4 x... 1)
0,15	0,15	0,3	8	M 1,6x0,2	3,1	5	5 x... 1)
						6	6 x... 1)
0,2	0,2	0,45	10	M 2,3x0,25	4,4	8	8 x... 1)
			12	M 2,5x0,35	5,2	10	10 x... 1)
0,25	0,25		14	M 3 x0,35	6,2	12	12 x... 1)

Z 48735 / ...

Quartal - Schriftstempel
 Quarter - marking insert
 Insert Trimestre

Mat.: 1.4112/58 HRC

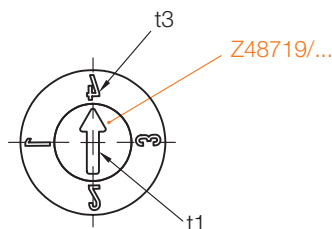
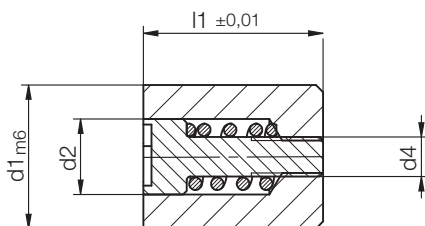

t1, t3 = Schrifttiefe
 Depth of characters
 Profondeur de la gravure

t3	t1	l1	d4	d2	d1	Nr. / No. 1)
0,09	0,18	4	M 0,8x0,2	1,4	2,6	Z 48735 / 2,6
0,1				1,5	3	3
0,11	0,22	5	M 1,1x0,25	2,1	4	4
0,15	0,3	8	M 1,6x0,2	3,1	5	5
					6	6
0,2	0,45	10	M 2,3x0,25	4,4	8	8
		12	M 2,5x0,35	5,2	10	10
0,25		14	M 3 x0,35	6,2	12	12

Z49/...

Kernstift, mit Demontagegewinde
 Core pin, with extracting thread
 Broche, avec filetage de démontage

Mat.: 1.2343 / 1370 N/mm²

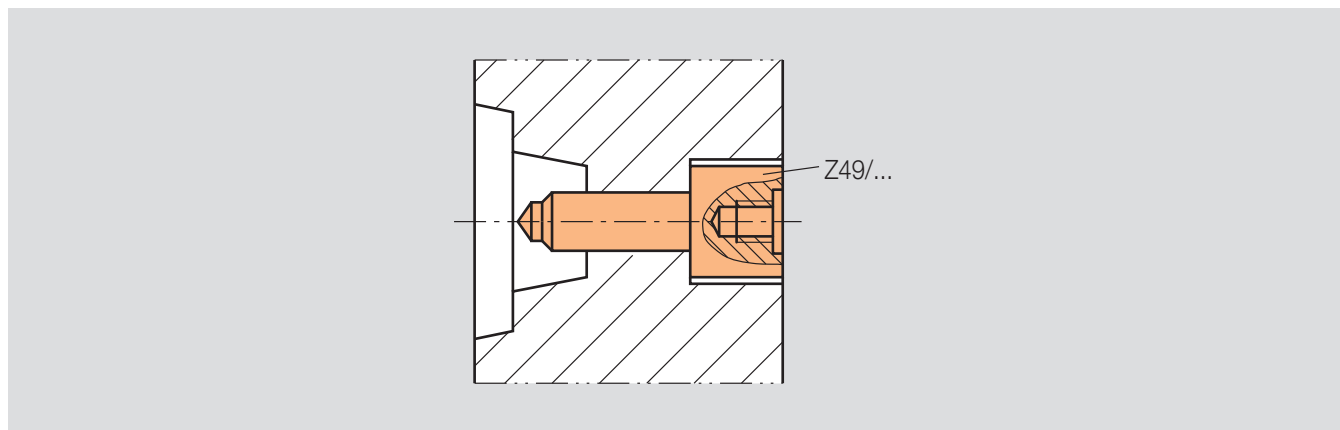
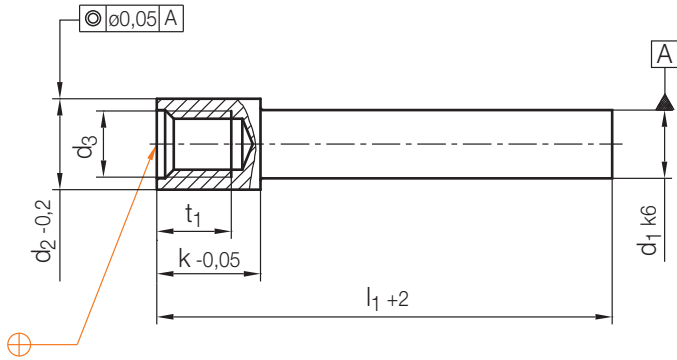

d ₂	d ₃	t ₁	k	d ₁	l ₁	Nr./No.
6	M4	5	10	3	63	Z49/3 x 63
					125	3 x 125
				3,5	63	3,5x 63
					125	3,5x125
8	M5	7	12	4	63	4 x 63
					125	4 x 125
				4,5	63	4,5x 63
					125	4,5x125
9	M6	9	14	5	80	5 x 80
					160	5 x 160
				5,5	80	5,5x 80
					160	5,5x160
10	M6	9	14	6	80	6 x 80
					160	6 x 160
				6,5	80	6,5x 80
					160	6,5x160
13	M8	10	16	8	80	8 x 80
					160	8 x 160
				8,5	80	8,5x 80
					160	8,5x160

d ₂	d ₃	t ₁	k	d ₁	l ₁	Nr./No.
15	M10	12	18	10	100	Z49/10 x 100
					200	10 x 200
				10,5	100	10,5x100
					200	10,5x200
18	M12	14	22	12	100	12 x 100
					200	12 x 200
				12,5	100	12,5x100
					200	12,5x200
20	M12	14	22	14	100	14 x 100
					200	14 x 200
				14,5	100	14,5x100
					200	14,5x200
22	M16	18	25	16	100	16 x 100
					200	16 x 200
				16,5	100	16,5x100
					200	16,5x200